

KENFLO<sup>®</sup> 肯富来

## Centrifugal Pumps

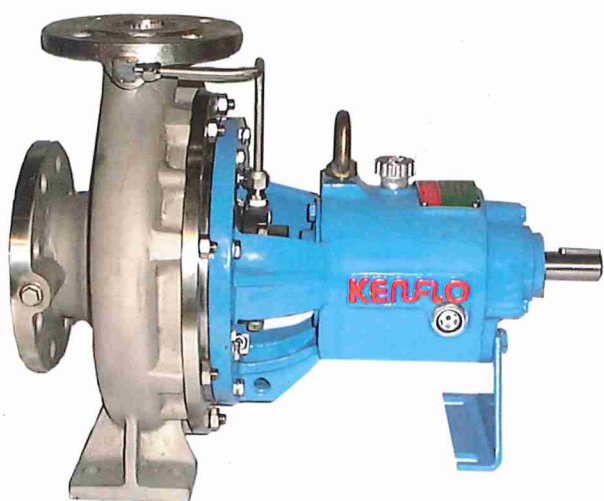

通过ISO9001质量管理体系认证  
华信技术检验有限公司认证

Obtaining ISO9001 Quality System Certificate  
Registered by Vouching Technical Inspection Ltd.

**广东肯富来泵业集团 广东省佛山水泵厂有限公司**

KENFLO PUMPS GROUP GUANGDONG FOSHAN PUMP FACTORY CO.,LTD.

# Product Range

<b>ISO</b> Single Stage Centrifugal Pumps .....	1
<b>KMP</b> Close-coupled Single Stage Pumps .....	1
<b>KCC</b> Standardized Chemical Centrifugal Pumps .....	2
<b>KGP</b> In-line Pumps .....	2
<b>KPS</b> Double Suction Split Casing Pumps.....	3
<b>KDW</b> Horizontal Multistage Centrifugal Pumps.....	3
<b>KDL</b> Vertical Multistage Centrifugal Pumps.....	4
<b>KHP</b> Horizontal Axially Split Casing Multistage Pumps .....	4
<b>XA</b> Single Stage Centrifugal Pumps.....	5
<b>CK<sub>1</sub>, CKX</b> Close-coupled Single Stage Pumps .....	6
<b>GD, GDR</b> In-line Pumps .....	6
<b>KG, KGR ,G,GR</b> In-line Pumps.....	7
<b>XBD</b> Fire-fighting Pumps .....	8
<b>D, VMD</b> Horizontal/Vertical Multistage Pumps .....	9
<b>DL, DLR</b> Vertical Multistage Centrifugal Pumps.....	9
<b>LG</b> Vertical Multistage Centrifugal Pumps .....	10
<b>DS, DLS, VS</b> Vertical Multistage & Multioutlet Pumps.....	10
<b>VMP</b> Vertical Multistage Centrifugal Pumps.....	11
<b>QW</b> Submersible Sewage Pumps .....	11
<b>FB2R, FB2P</b> Packaged Pressure Systems .....	12
<b>FBJ(S)</b> Pressure Boosting Systems .....	12
<b>ZW</b> Self-priming Non-clogging Sewage Pumps .....	13
<b>WZ</b> Multistage Self-priming Peripheral Pumps.....	13
<b>FSR ,TC, NS(SS)</b> Self-priming Pumps.....	13
<b>YZ</b> Axial Flow Pumps .....	13
<b>KYW</b> Submersible Sewage Pumps .....	13

## ISO Single Stage Centrifugal Pumps

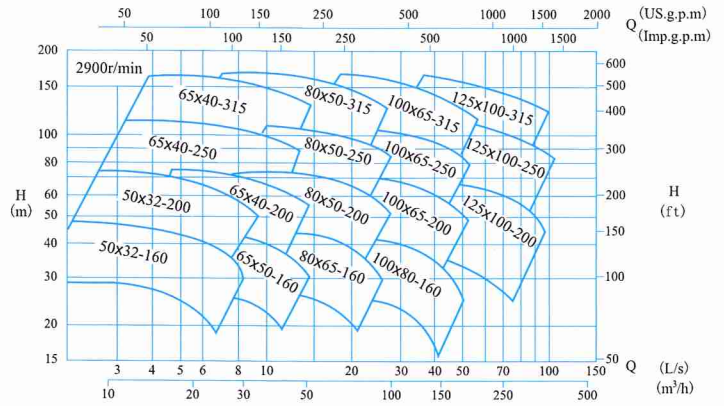

### ■ Features and Benefits

Manufactured to ISO2858 and ISO9908 standards, design of robust construction, high interchangeability and high efficiency and low NPSH. Back-pull-out design allows for easy maintenance and repair as the rotating element can be removed without dismantling the casing and the pipes.

### ■ Model Designation

ISO 200 X 150-500

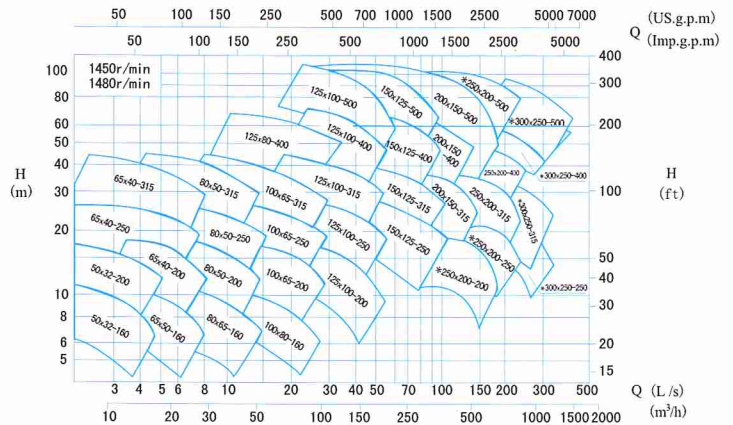
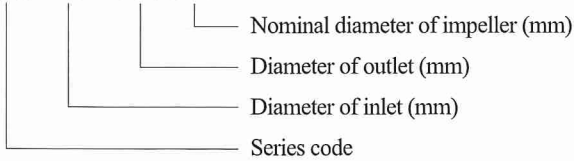

## KMP Close-coupled Single Stage Pumps

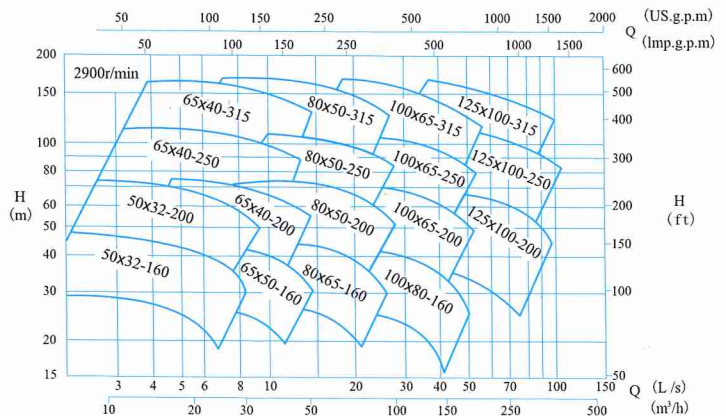

### ■ Features and Benefits

Back-pull-out motorpumps made in accordance with ISO 2858 and ISO 9908 standards. Compact design, high reliability, energy saving and low NPSH. Suitable for use in air conditioning, fire fighting, water supply and treatment, irrigation and other general industrial applications.

### ■ Model Designation

KMP 125 X 100-250

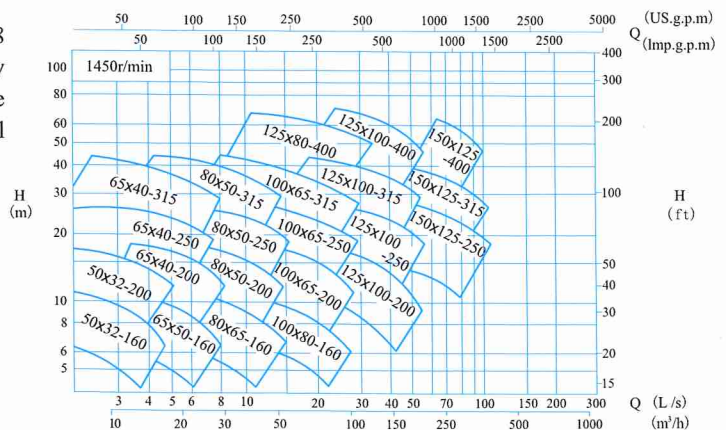
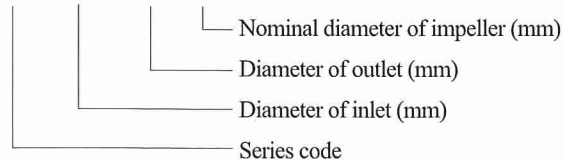

## KCC Standardized Chemical Centrifugal Pumps

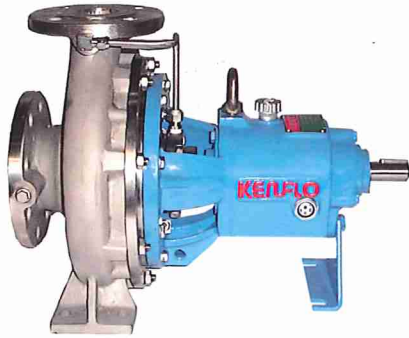

### Features and Benefits

New development from Kenflo to supersede traditional IH Series with much better hydraulic performance and higher operation reliability. Conical design of shaft-impeller connection and radial sealing under patent protection. Bearing arrangement in accordance with API610 standard. Optional cooling/ heating chamber for shaft seal, radially split type of packing gland for easy maintenance.

### Model Designation

KCC 80 X 50-250

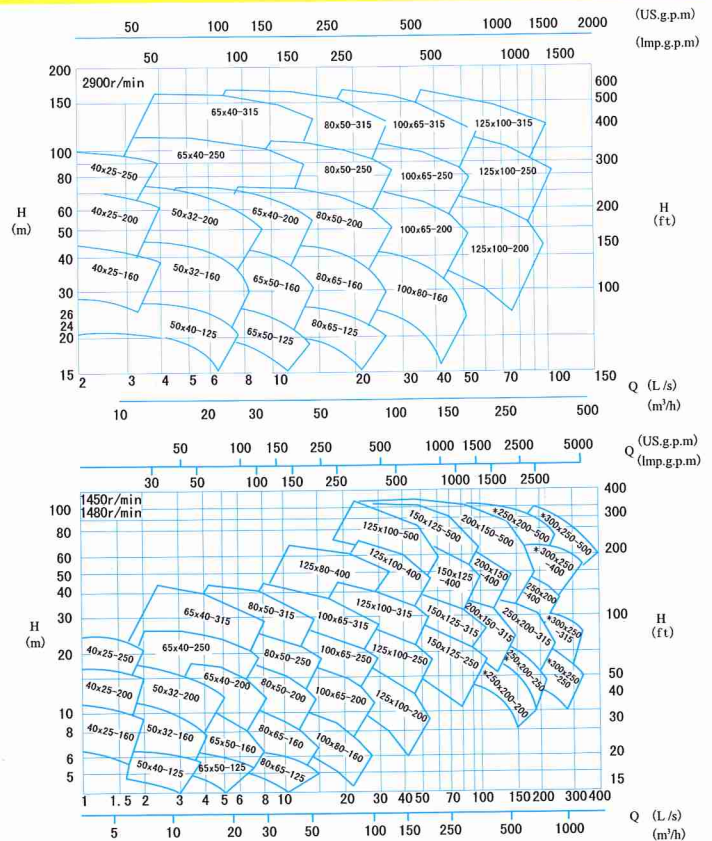
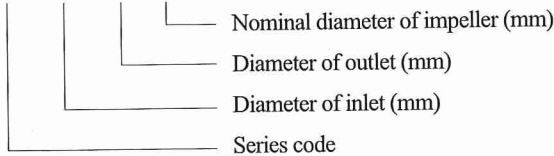

## KGP In-line Pumps



### Features and Benefits

Novel design; power-saved; simple and compact structure; high parts interchangeability; wide performance coverage.

### Model Designation

KGP 80 - 315

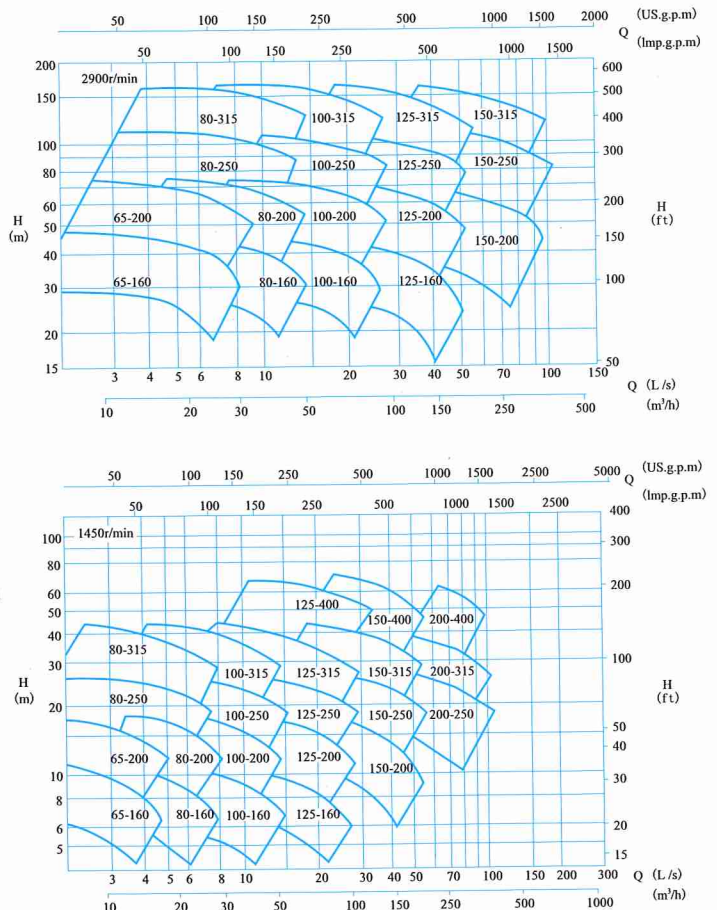
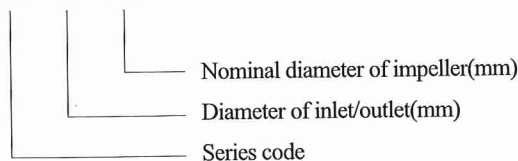

**KPS Double Suction Split Casing Pumps**



**Features and Benefits**

Built to ISO9908 standard, latest computer-aided design methods and CFD technology have ensured excellent hydraulic profile with high efficiency, quiet and smooth operation. Rugged casing, double-flow impeller with blades offset for low pulsation and nil axial thrust, replaceable wear rings, two-sided drive.

**Model Designation**

KPS 50-1000

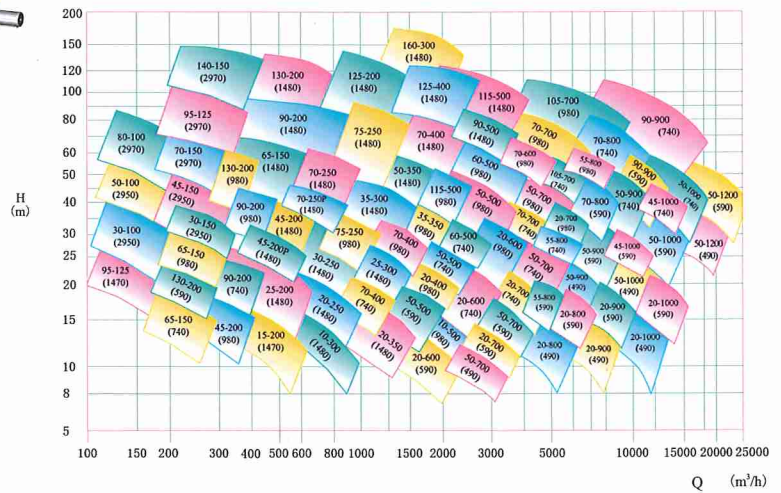
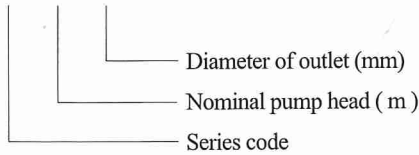

**KDW Horizontal Multistage Centrifugal Pumps**



**Features and Benefits**

Compact structure, various sealing forms, high efficiency and reliability, excellent anti-cavitation ability

**Model Designation**

KDW 65 X 4

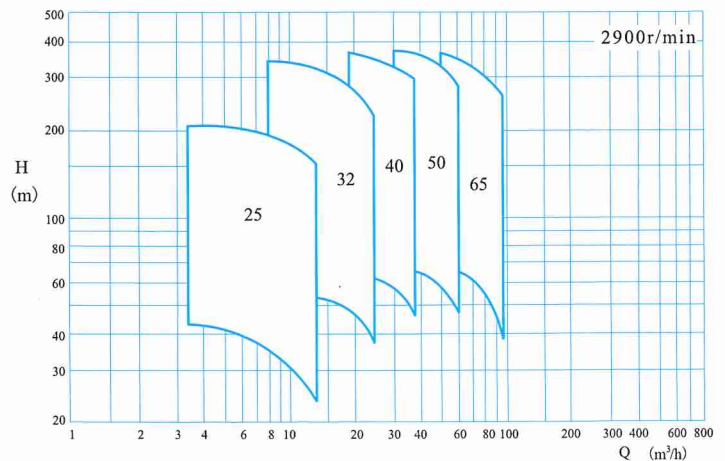
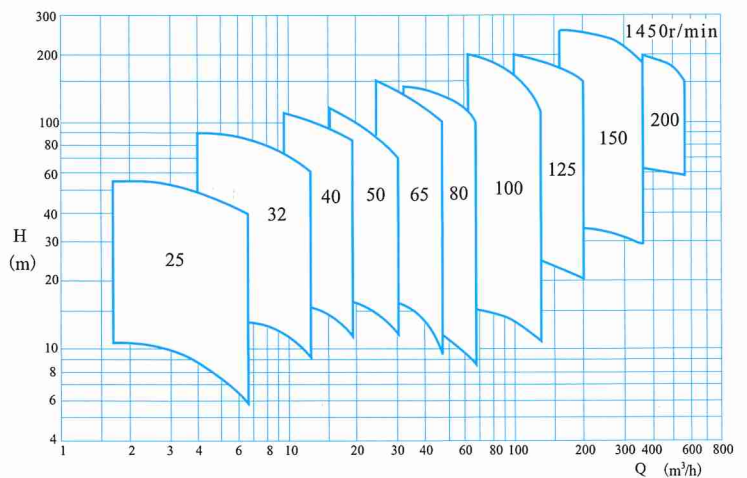
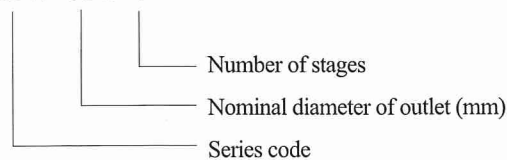

**KDL Vertical Multistage Centrifugal Pumps**

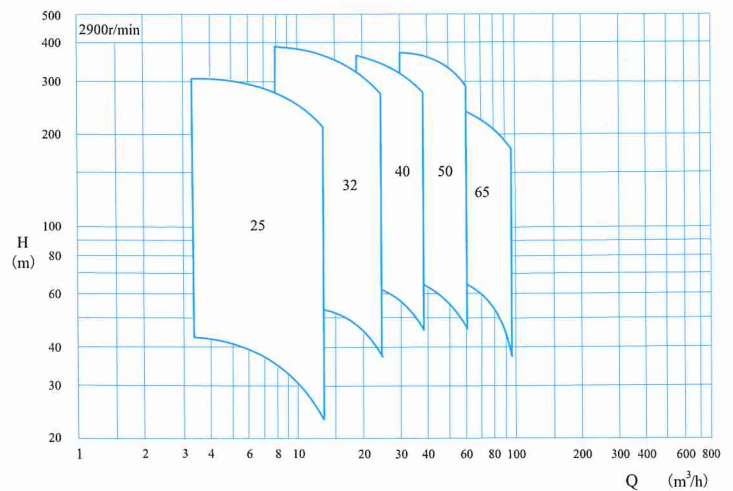
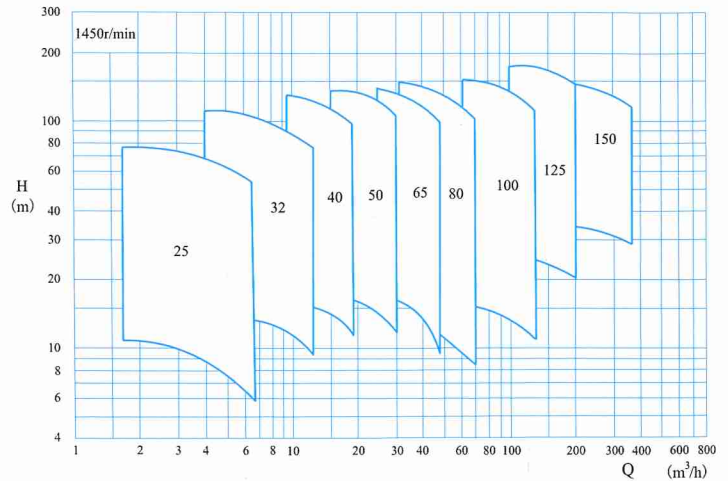

**Features and Benefits**

Compact structure, decent appearance, under protection of ZL023728434, both gland packing and mechanical seal available, water bearing design under protection of ZL02250656.X, easy maintenance. Mainly for transferring pure water and liquid with minor impurity, capable of replacing wide range of other existing vertical multistage pumps

**Model Designation**

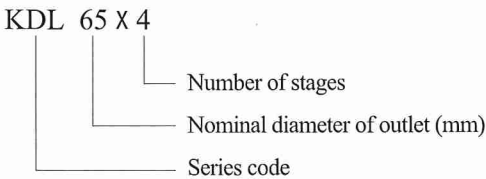

**KHP Horizontal Axially Split Casing Multistage Pumps**



**Features and Benefits**

High efficiency and power-saved; sturdy and durable; easily maintained. Suitable for pumping water and liquid, petroleum or other light corrosive liquid with similar physical and chemistry character to water. The maximum temperature of the discharged liquid is 150°C. Widely used in petroleum, chemical plant, steel and mining.

**Model Designation**

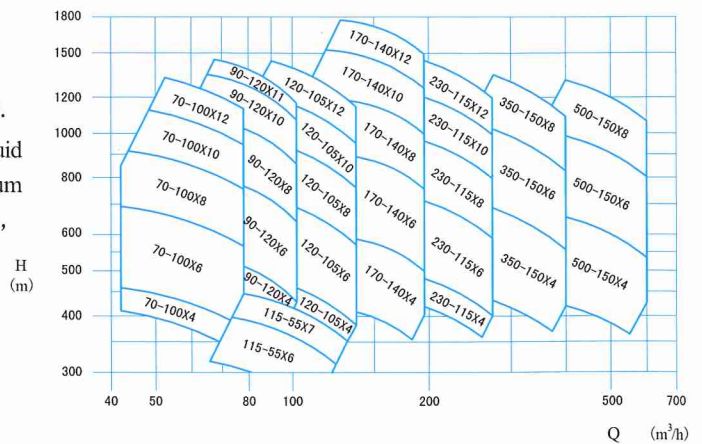
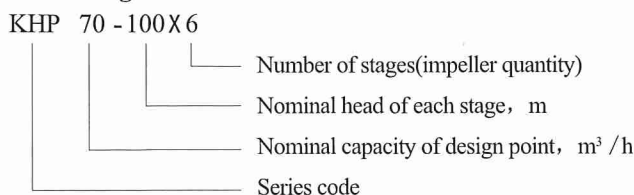

**XA Single Stage Centrifugal Pumps**



**Features and Benefits**

End suction pumps built to BS EN 733 ( Ex DIN 24255 ) Standard and ISO9908 standard. Back-pull-out design, excellent anti-cavitation capability, wide range of high efficiency performance, high parts interchangeability. Various materials available. Well recognized economical DIN standard pumps.

**Model Designation**

XA 32 / 26

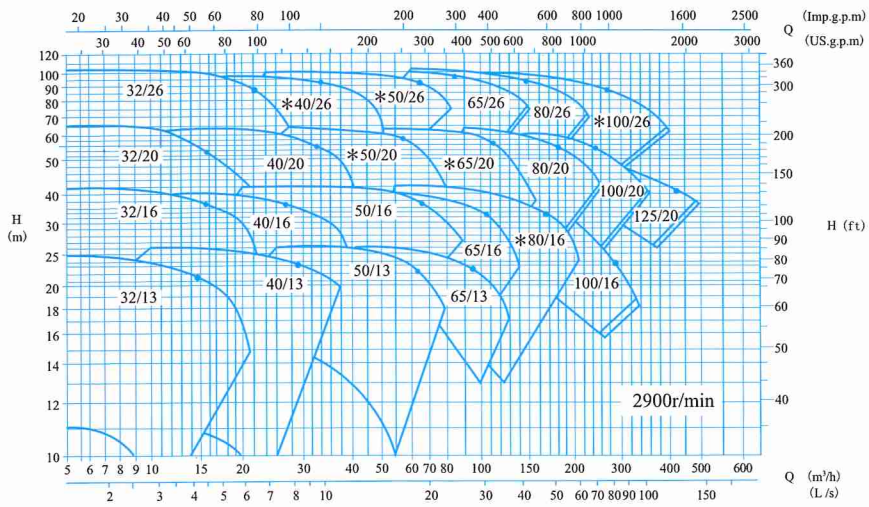
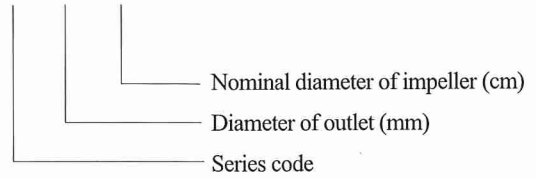

Models with \* are not recommended. Try to choose the corresponding ISO series.

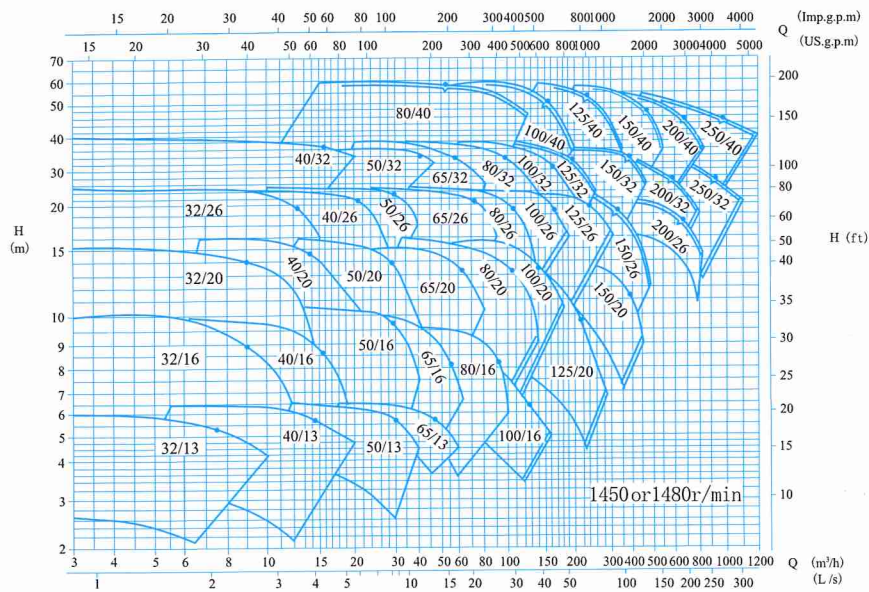

Note: For 250/32, 250/40 n=1480r/min

**CK1, CKX Close-coupled Single Stage Pumps**



**Features and Benefits**

Close-coupled with motor, simple and compact structure, small size and low weight, in accordance with BS EN 733 (Ex DIN 24255)

**Model Designation**

CK1(CKX) 50/20 H

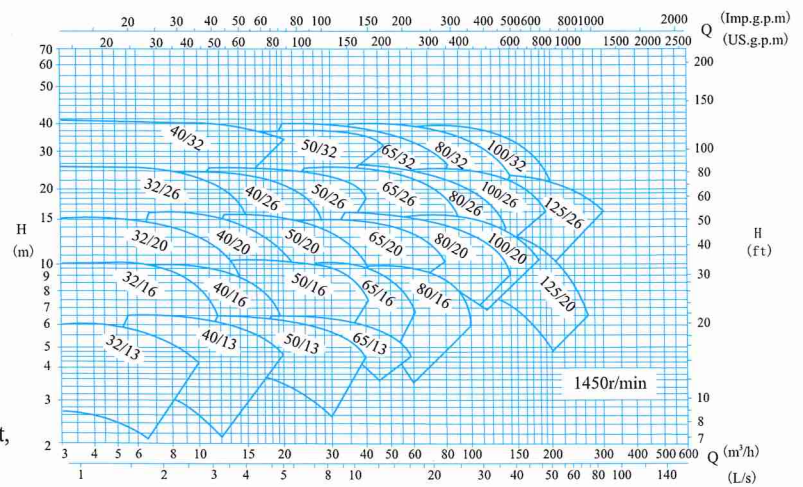
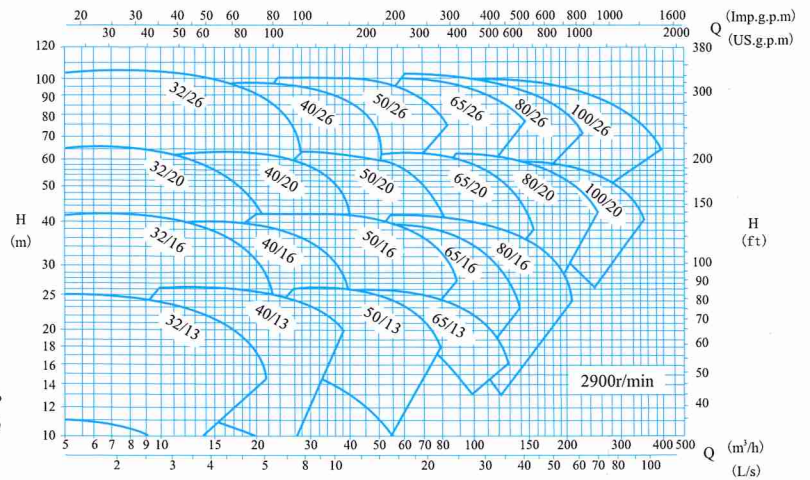
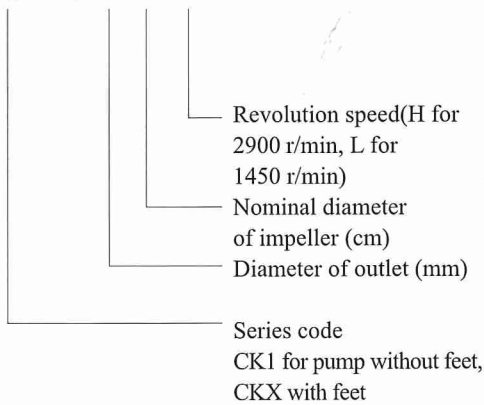

**GD, GDR In-line Pumps**



**Features and Benefits**

Same shaft shared by pump and motor. In-line design for easy installation.

**Model Designation**

GD (GDR) 100-19

GD: In-line pump  
 (GDR): Hot water in-line pump  
 100: Diameter of inlet and outlet (mm)  
 19: Rating head (m)

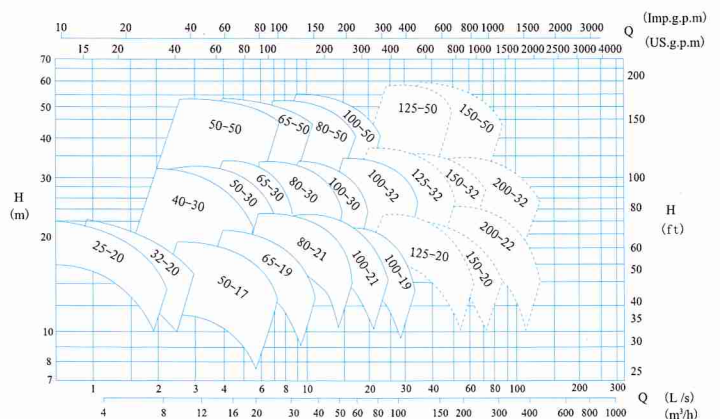

Note: Real line represents the performance at the speed of 2900 r/min, broken line represents at 1450 or 1480r/min.



**KG, KGR In-line Pumps**



**Features and Benefits**

In-line design with top-pull-out feature, fitted with IEC standard motor, simple and compact structure, high parts interchangeability, flexible installation form, reliable operation and convenient maintenance. Nominal specifications to BS EN 733 ( Ex DIN 24255 )standard.

**Model Designation**

KG(R) 80-65/26

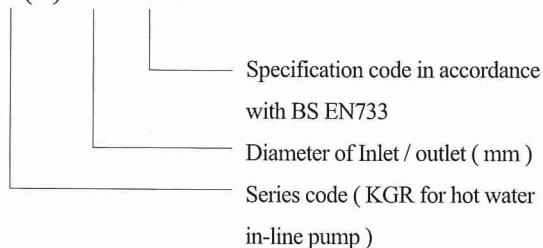

**KG, KGR Type**

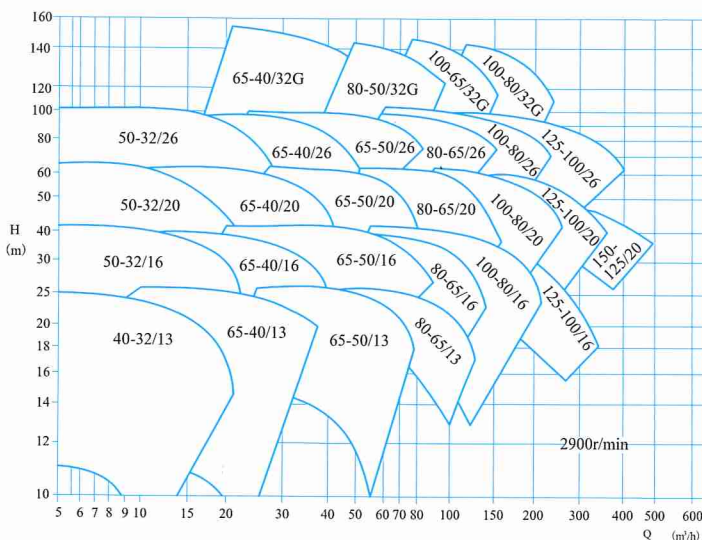
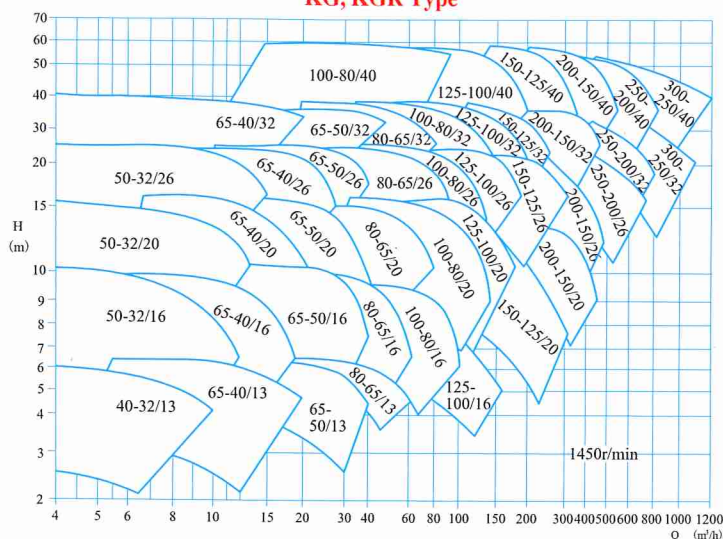

**KYW submersible sewage pumps**



**Features and Benefits**

Special design of impeller and volute casing, excellent performance in pollution discharge, easy start-up, no leakage

**Performance Range**

Capacity: 10~1200 m³/h  
Pump head: 7~40m

## XBD Fire-fighting Pumps

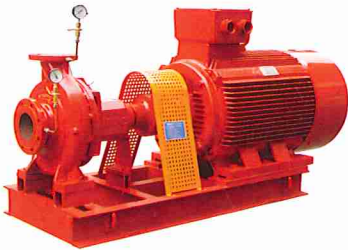
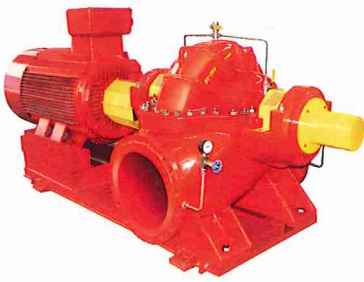

### XBD-S4 Type

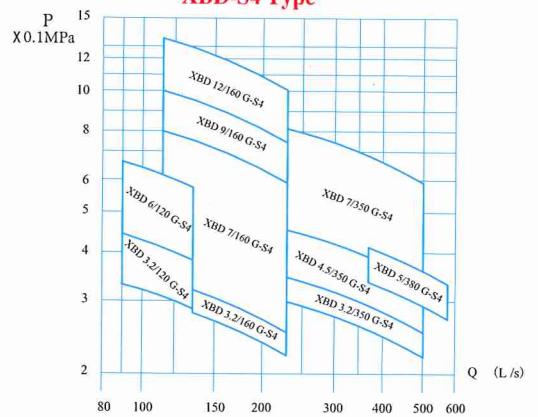

### XBD-G2 Type

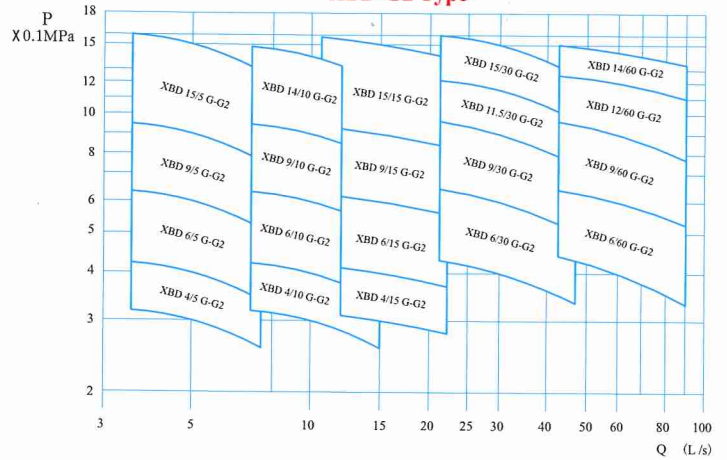

### XBD-Y2 Type

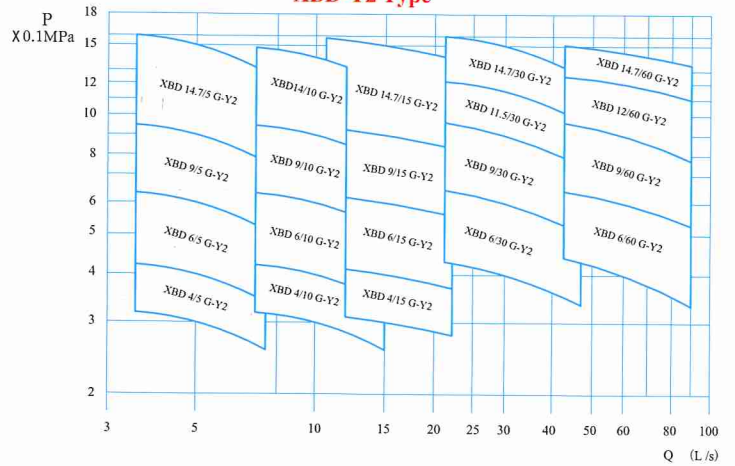

### XBD-D4 Type

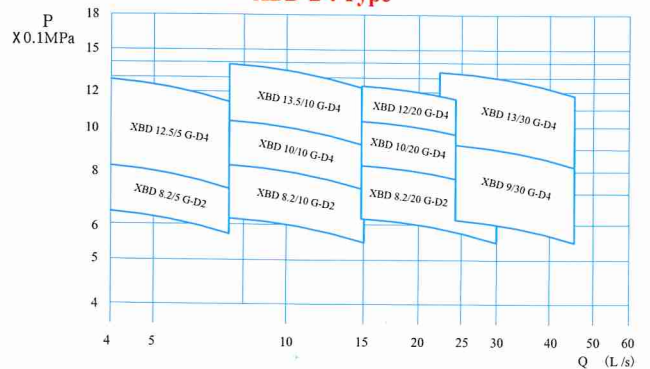

### Features and Benefits

Frictional parts of relative movement are made of stainless material.  
In accordance with GB6245-2006 standard.

### Model Designation

XBD □/□ □-□-□

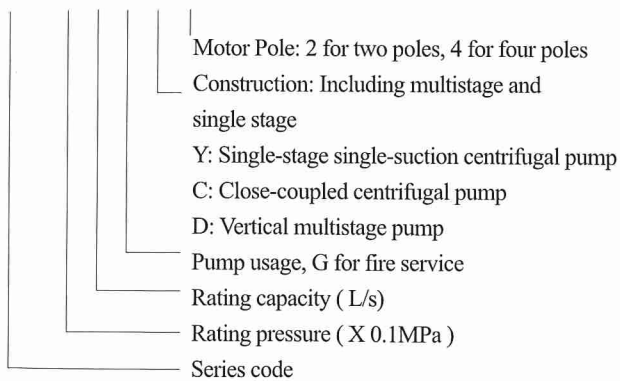

## D, VMD Horizontal / Vertical Multistage Pumps

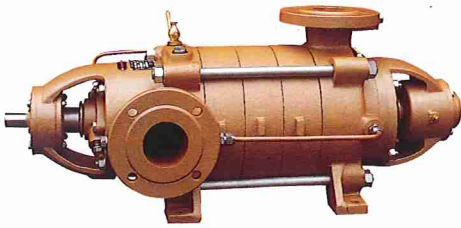

### ■ Features and Benefits

High head. Axial thrust is dynamically balanced.

### ■ Model Designation

- D □ X □
- ├── Number of stages
- ├── Pump head of individual stage (m)
- ├── Series code ( Horizontal single suction multistage sectional type )
- └── Diameter of outlet (mm)
- VMD ─── Series code ( Vertical single suction multistage sectional type )

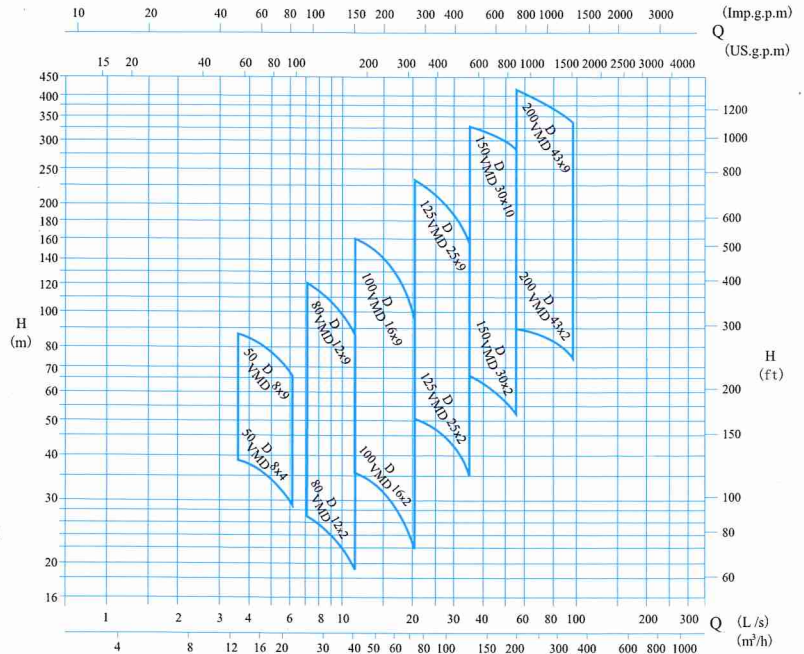

## DL, DLR Vertical Multistage Centrifugal Pumps



### ■ Features and Benefits

Use of two angular contact ball bearings, axial thrust well balanced. Different materials available.

### ■ Model Designation

- DL □ X □
- ├── Number of stages
- ├── Pump head of each stage (m)
- ├── Series code
- └── Diameter of outlet (mm)
- DLR ─── Series code ( hot water pump )

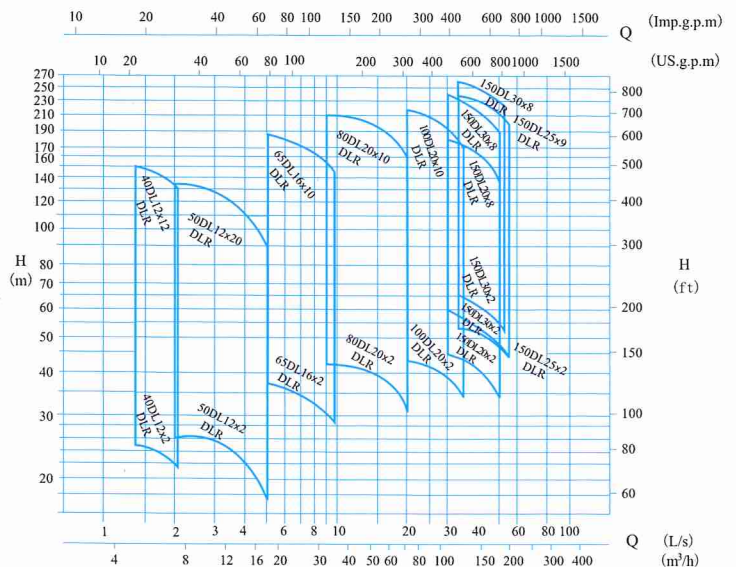

## LG Vertical Multistage Centrifugal Pumps



### ■ Features and Benefits

Small flow capacity, high head and efficiency, suitable for high buildings water supply and pressure boosting in fire service system

### ■ Model Designation

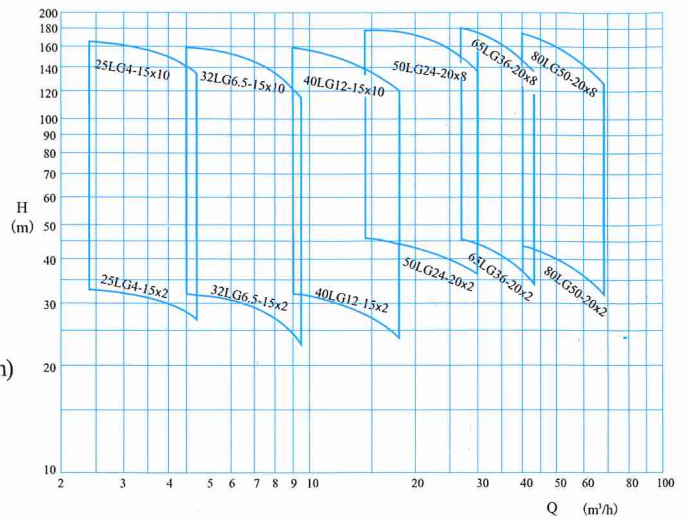
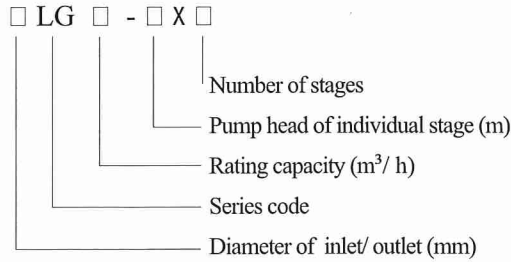

## DS, DLS, VS Vertical Multistage & Multioutlet Pumps



### ■ Features and Benefits

Suitable for water supply for different floors and zones with different pressures at the same time. Single pump of versatile usage.

### ■ Model Designation

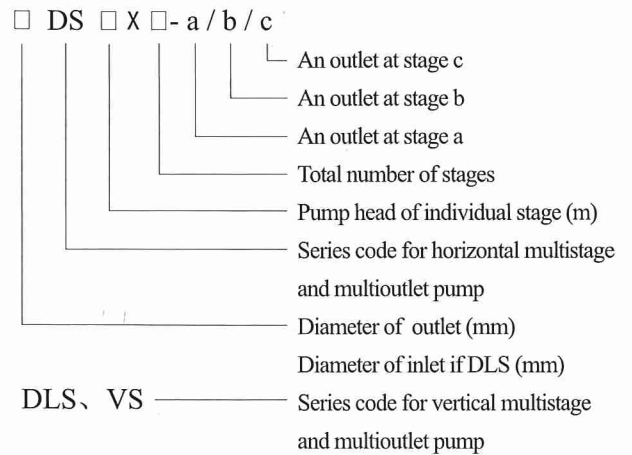

**DS, VS Type**

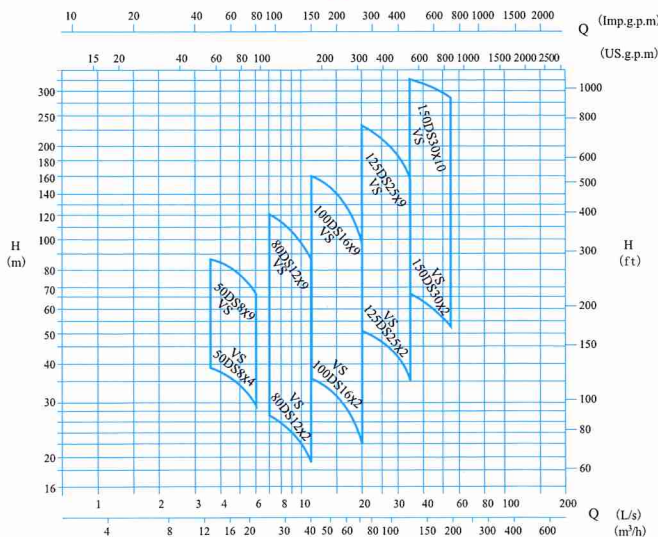

**DLS Type**

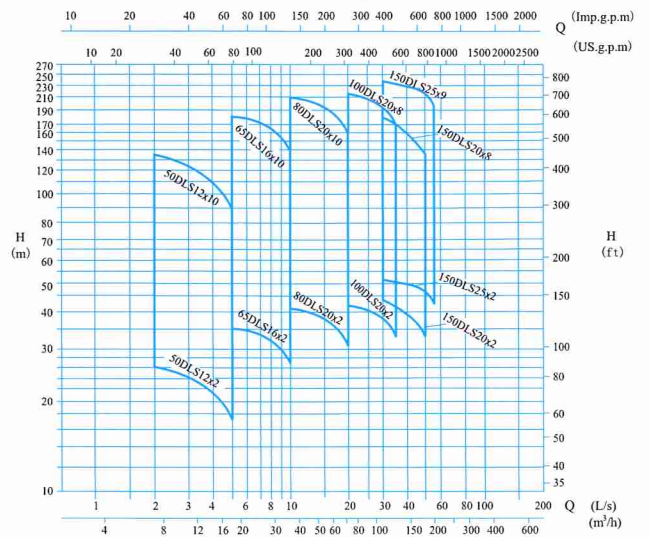

**VMP Vertical Multistage Centrifugal Pumps**



**Features and Benefits**

Compact structure, decent appearance

**Model Designation**

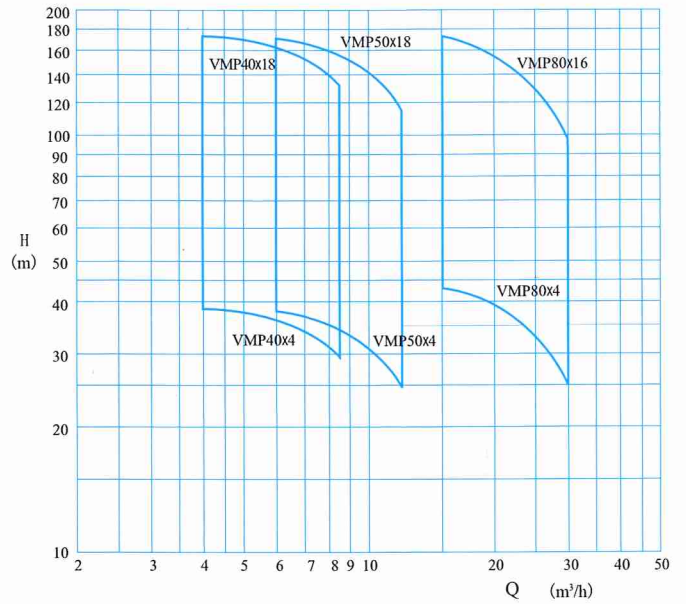
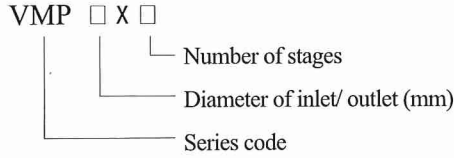

**QW Submersible Sewage Pumps**



**Features and Benefits**

Special design for impeller and volute casing, excellent performance in contamination drainage, full protections, various installation ways. Control panel available on request.

**Model Designation**

100 QW 110-15-7.5

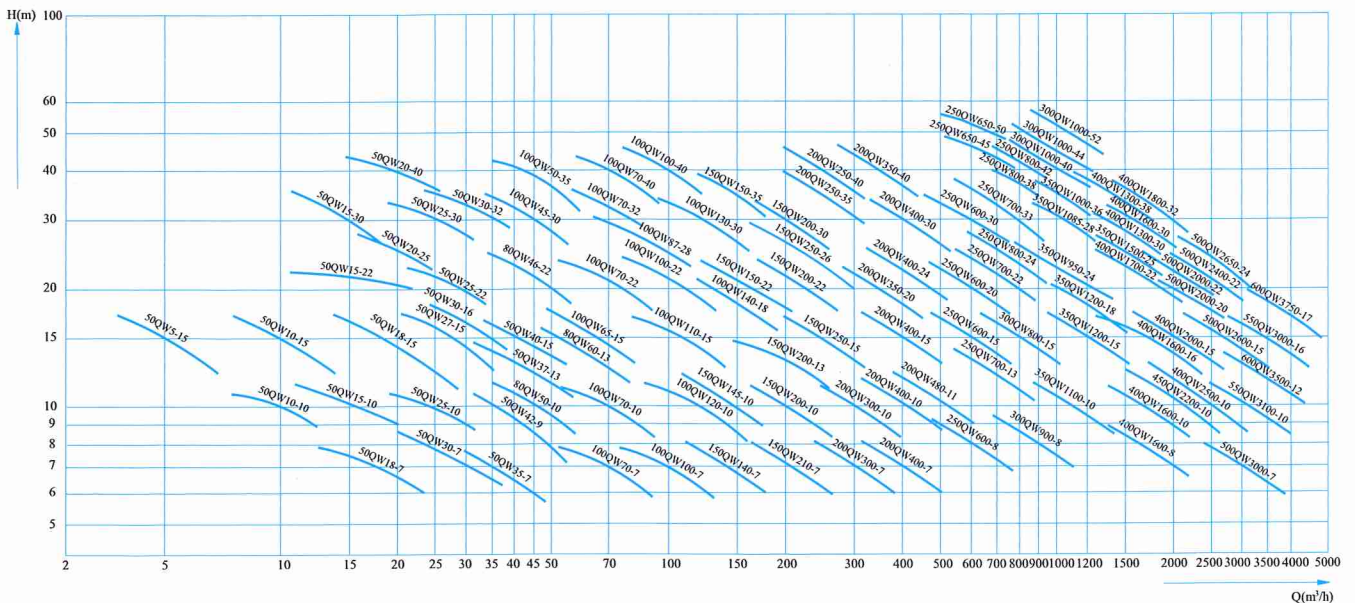
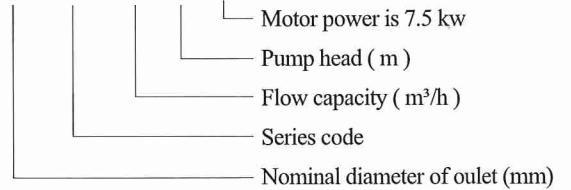

**FB2R, FB2P Packaged Pressure Systems**



**Features and Benefits**

Start and stop automatically corresponding to pre-set pressure, widely used in fire service and constant pressure spraying systems.

**Model Designation**

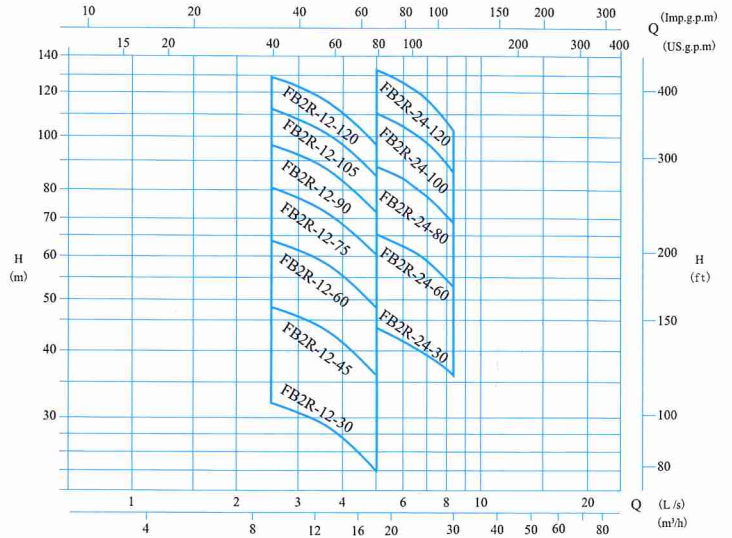
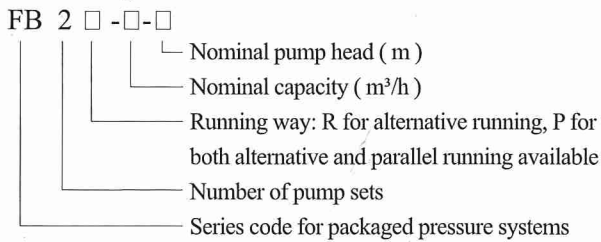

**FBJ(S) Pressure Boosting Systems**

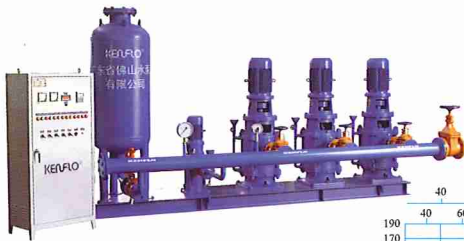

**Features and Benefits**

It is a stepless variable speed control system equipped with frequency converter, controlled by micro-processor. High energy saving, stable pressure, full protection. User friendly controlling and monitoring elements and self-priming vacuum package can be available upon request.

**Model Designation**

- FBJ S - 32 - 28 (II)
- (II)---Number of main pump sets
  - 28---Nominal pump head of individual pump (m)
  - 32---Total nominal capacity of pump sets (m<sup>3</sup>/h)
  - S----Sign of affiliated pneumatic tank
  - FBJ---Series code for pressure boosting systems

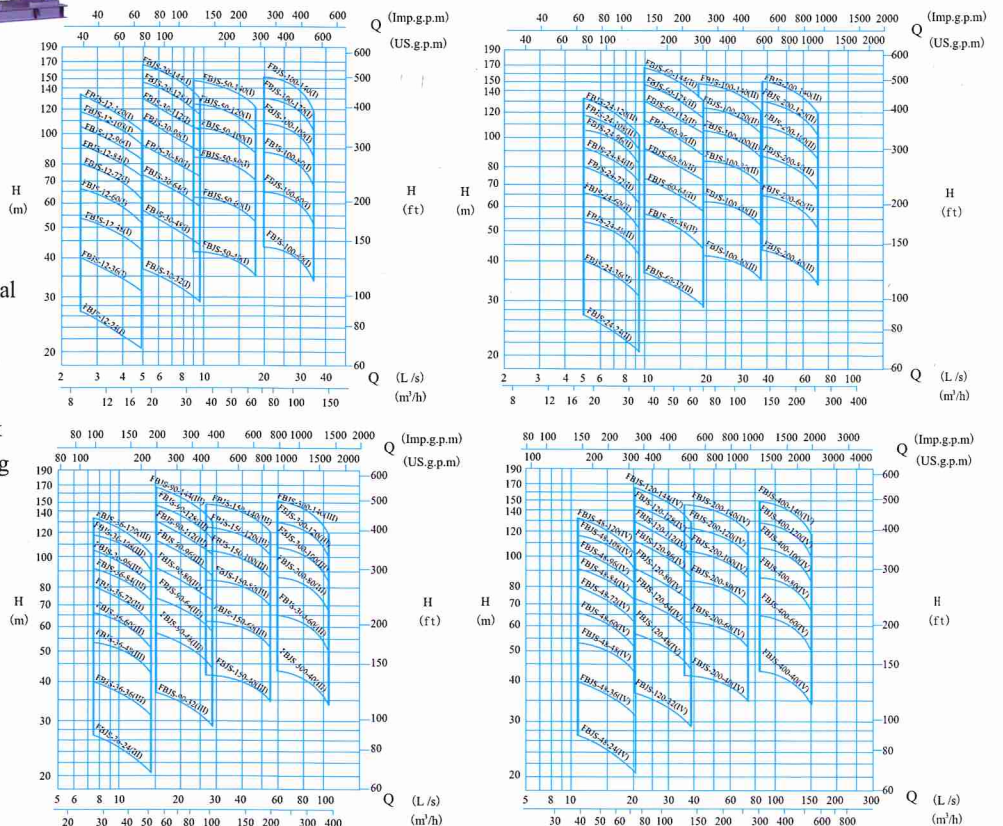

## ZW Self-priming Non-clogging Sewage Pumps



### ■ Features and Benefits

Self-priming and non-clogging, excellent performance in contamination drainage, low noise, little vibration, strong ability against entwinding

### ■ Model Designation

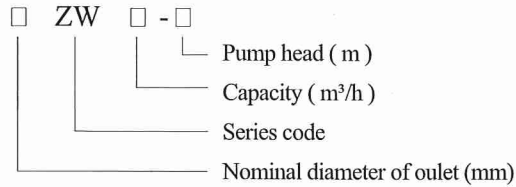

## WZ Multistage Self-priming Peripheral Pumps

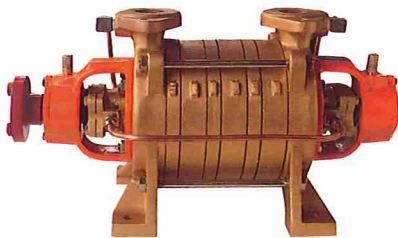

### ■ Features and Benefits

Self-priming, multistage, suitable for applications where both high pump head and low capacity are required

### ■ Performance Range

Capacity: 1.8~18 m<sup>3</sup>/h

Pump head: 22~168 m

## FSR, TC, NS(SS) Self-priming Pumps



### ■ Features and Benefits

Self-priming, without foot valve. Feed a little water into the casing when starting for the first time ( no such a need when starting in the future )

### ■ Performance Range

Capacity: 9~240 m<sup>3</sup>/h

Pump head: 6~27 m

## YZ Axial Flow Pumps



### ■ Features and Benefits

Pipe like structure, suitable for applications where low pump head is required

### ■ Performance Range

Capacity: 40~900 m<sup>3</sup>/h

Pump head: 1.2~3 m

## 广东肯富来泵业集团 广东省佛山水泵厂有限公司

KENFLO PUMPS GROUP  
GUANGDONG FOSHAN PUMP FACTORY CO.,LTD.

地 址: 广东省佛山市河滨路14号  
Add: No.14,Hebin Road,Foshan City,Guangdong,P.R.China 528000

销售电话: (0757) 82801027 82818421

82819544 82801095

Import & Export Dept

服务热线: (0757) 82812555

Tel: +86 757 82801021 82813427 82801097

传 真: (0757) 82816443 82822323

Fax: +86 757 82837225

邮 编: 528000

网 址: [www.kenflo.com](http://www.kenflo.com)

Website: [www.kenflo.com](http://www.kenflo.com)

E-mail: [kenflo@kenflo.com](mailto:kenflo@kenflo.com)

E-mail: [overseas@kenflo.com](mailto:overseas@kenflo.com)

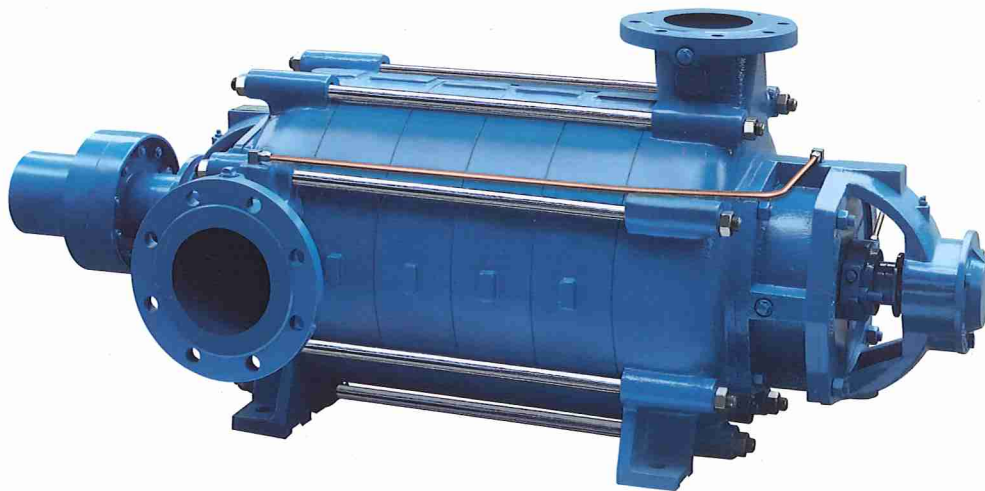

■ *Please contact us if you want to know more details about*

*Centrifugal Pump, Vacuum Pump and Compressor*



KENFLO® 肯富来

CBF 水环真空泵

CBF LIQUID-RING VACUUM PUMPS



有效期2006-2009年



通过ISO9001质量体系认证  
华信技术检验有限公司注册认证  
美国FM Approvals注册认证

Obtaining ISO9001 Quality System Certificate  
Registered by FM Approvals America  
and Vouching Technical Inspection Ltd.

广东省佛山水泵厂有限公司

GUANGDONG FOSHAN PUMP FACTORY CO., LTD.



公司远眺 Bird's eye View of the Company

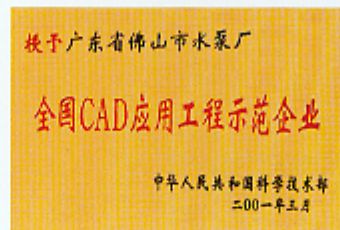

### 来人指路 The ways to the Company

1. 广佛公路→文昌路→货站路→货站东路→河滨路·佛山水泵厂有限公司  
Guangfo Highway → Wen Chang Road → Kuo Zhan Road → Kuo Zhan East Road → Hebin Road · Guangdong Foshan Pump Factory Co., Ltd.
2. 佛山大道→红棉路→汾江中路→中山路→河滨路·佛山水泵厂有限公司  
Foshan Avenue → Hong Mian Road → Fen Jiang Zhong Road → Zhong Shan Road → Hebin Road · Guangdong Foshan Pump Factory Co., Ltd.
3. 市东上路→南堤路→中山路→河滨路·佛山水泵厂有限公司  
Shi Dong shang Road → Nan Ti Road → Zhong Shan Road → Hebin Road · Guangdong Foshan Pump Factory Co., Ltd.
4. 乘车路线: 火车站14路、106路、108路、109路公共汽车至中山公园换乘136路车到佛山水泵厂有限公司  
Bus Routes: Take the bus No.114、106、108 or 109 and change bus No.130 in Zhong Shan Park to the Company

### 尊敬的肯富来用户们:

承蒙选购、使用KENFLO产品, 谨致万分谢意。

### 产品概述

CBF系列水环真空泵是佛山水泵厂有限公司推出的新一代节能产品。通常用于抽吸不含固体颗粒、不溶或微溶于工作液的气体。泵一般以水作为工作液。该系列产品的结构和性能有如下特点:

### 节能效果显著

- 在200~1013mbar的抽吸区域, 对泵的过流部件作了优化的水力设计, 大大提高了泵在这一区域的运行效率。
- 在200~1013mbar的使用范围内, 比2BE1水环真空泵更加节能。

### 运行可靠性高

- 在获得相同抽气量的同时, CBF水环真空泵具有更低的叶轮线速度, 泵的运行更加平稳可靠, 噪声更低。

### 结构优点突出

- 装有柔性阀板的排气口, 能自动调节排气角, 有效地防止了排气过程中的过压缩, 使泵在不同的吸入压力下高效运行。
- 配有自动排水阀, 控制泵的起动液位, 避免了过载起动。
- 当采用工作液闭式循环时, 可以大大减少水的损耗。通过真空泵的自吸能力, 将被冷却的工作液引入泵内, 无须另设增压装置。
- 当泵体带隔板时, 一台真空泵可以同时抽吸不同的真空。
- 泵体与侧盖采用法兰式连接, 保证了大规格水环真空泵的整体刚性和抗震能力。当维修空间较小时, 可以实行卧式装拆。
- 填料压盖为分半结构, 可以整体拆出, 更换填料更方便。

### 环境适应性强

- 叶轮加强环采用内移式设计, 防止了杂质的滞留, 减少了水质结垢对泵的影响。
- 当过流部件采用不同牌号的不锈钢制造时, 可以满足不同的防腐蚀要求。
- 当过流部件喷涂瓷质高分子材料SEBF时, 在可以满足十分苛刻的防腐蚀要求的同时, 其光滑的表面可以有效地降低灰状物质的沉淀, 减缓结垢过程。

### 衔接性良好

- 当用户正在使用2BE1水环真空泵时, 如果抽吸真空在200~1013mbar, 选用相应的CBF水环真空泵, 无需变动连接管路, 在获得直接的节能效益的同时, 可以大大降低改造费用。
- 相应规格的2BE1水环真空泵, 部分零件与CBF互换, 可以降低用户的备件成本。

### 应用领域广泛

- 电力工业：负压除灰。
- 石油化工：真空蒸馏、真空结晶。
- 烟草行业中的真空系统。
- 造纸工业中的真空系统以及各种真空获得过程。
- 制气过程中的变压吸附。
- 煤炭及矿业：真空浮选与过滤。
- 矿井煤层的瓦斯排放。

### 工作原理

叶轮偏心地装在接近圆形的泵体内，当叶轮按图示箭头方向旋转时，因离心力的作用，注入泵内的液体被甩向泵体内壁，形成一个形状与泵体相似，厚度接近相等的液环。随叶轮一起旋转的液环内表面与叶轮轮毂之间形成一个月牙形空间，当叶轮由A点转到B点时，两相邻叶片之间所包围的容腔逐渐增大，气体由外界吸入。当叶轮由C点转到A点时，相应的容腔由大变小，使原先吸入的气体受到压缩，当压力达到大气压力时，气体被排出。

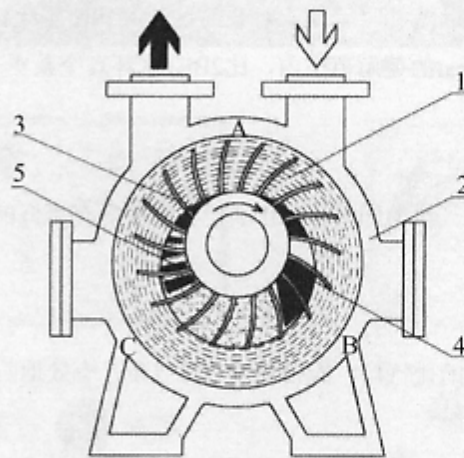

1. 水环
2. 泵体
3. 叶轮
4. 吸气口
5. 排气口

产品标准：Q/FP 2106-2007 液环真空泵、液环压缩机和液环真空压缩机组  
 备案号：QB/440600 23 535-2007

### 型号表示方法

C B F 4 1 0 - 2 B D 3

- 轴封型式代号。“3”为外供水填料密封，“4”为内供水填料密封。
- 传动方式代号。“D”为直联传动，“G”为减速机传动，“V”为皮带传动。
- 结构材料代号。“B”主要过流部件为普通材质，“B<sub>i</sub>”主要过流部件喷涂耐腐蚀瓷质材料SEBF。
- 最低吸入压力可达180mbar，高效抽吸范围在200~1013mbar。
- 泵体带隔板识别代号。“6”为泵体带隔板，“0”为不带隔板。
- 以厘米为单位的叶轮名义半径。
- 泵系列代号。

抽气速率曲线

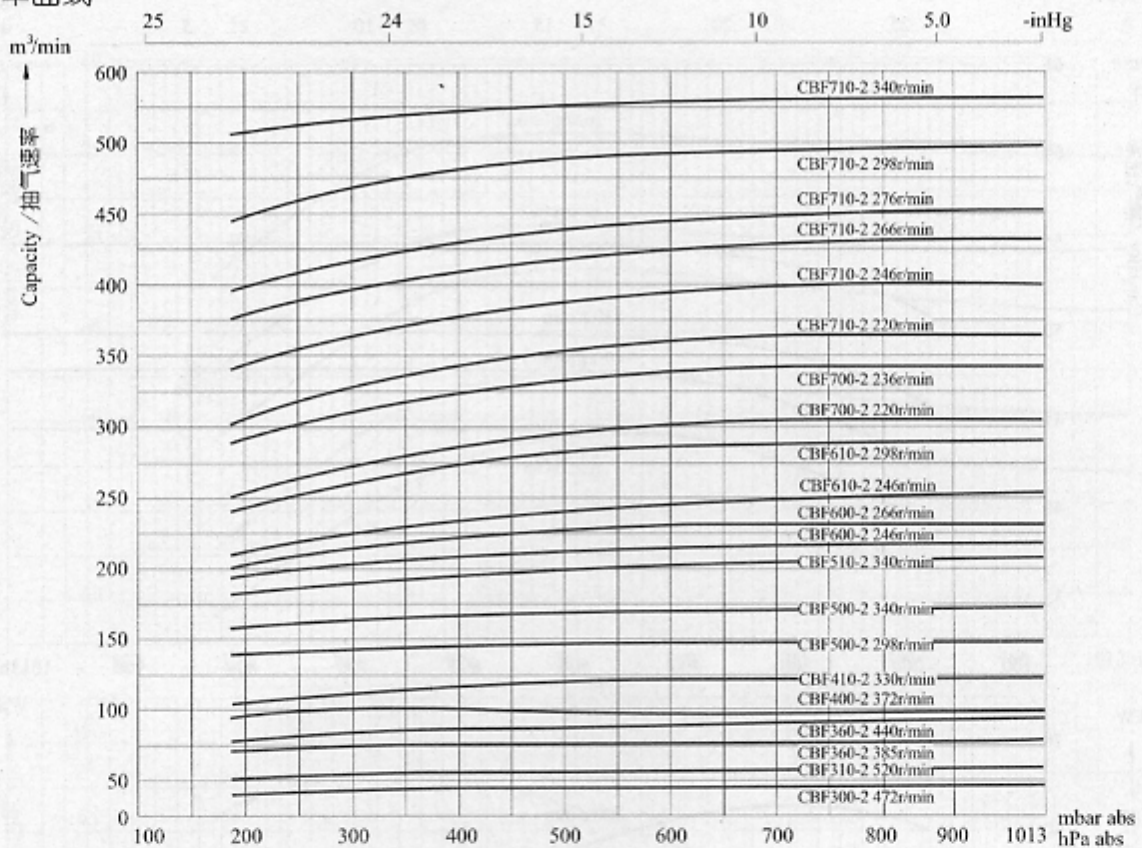

外形安装尺寸

型号 Type	外形安装尺寸 Overall and Mounting Dimensions																		
	a	b	c	e	f	g	H	l	m	n	s	k	h	u	v	ø	d	w	t
CBF300-2	1580	1360	825	1185	230	910	475	790	315	165	205	670	335	864	480	35	100	28	106
CBF310-2	1780	1360	825	1185	230	910	475	990	315	165	205	670	335	1064	480	35	100	28	106
CBF360-2	1985	1570	930	1370	285	1050	560	1150	335	165	245	800	395	1240	555	35	120	32	127
CBF400-2	2020	1865	1120	1625	335	1265	670	1110	355	200	285	950	475	1210	685	42	140	36	148
CBF410-2	2390	1865	1120	1625	335	1265	670	1480	355	200	285	950	475	1580	685	42	140	36	148
CBF500-2	2435	2160	1335	1875	385	1475	800	1450	375	240	285	1120	560	1590	775	42	160	40	169
CBF510-2	2655	2160	1335	1875	385	1475	800	1670	375	240	285	1120	560	1810	775	42	160	40	169
CBF600-2	2730	2560	1555	2220	435	1770	950	1700	400	240	370	1320	665	1880	875	48	180	45	190
CBF610-2	2980	2560	1555	2220	435	1770	950	1950	400	240	370	1320	665	2130	875	48	180	45	190
CBF700-2	3185	2965	1835	2560	490	2045	1120	2020	450	280	370	1600	790	2230	1025	48	200	45	210
CBF710-2	3445	2965	1835	2560	490	2045	1120	2280	450	280	370	1600	790	2490	1025	48	200	45	210

CBF300~710 外形安装尺寸图

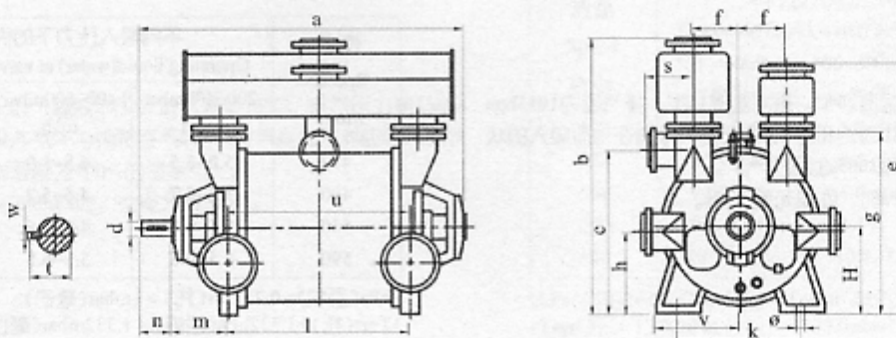

抽气速率、轴功率曲线

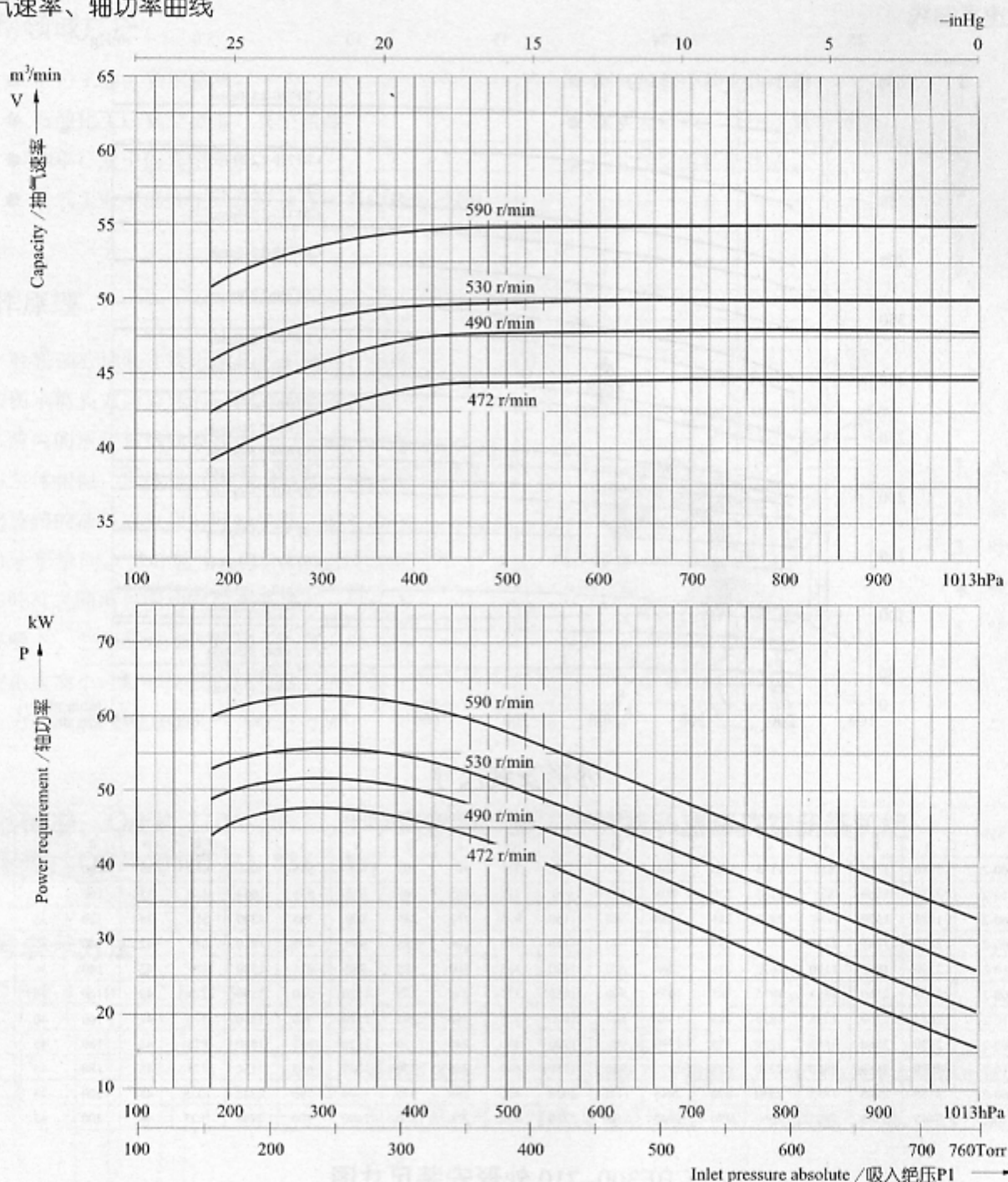

注:

1. 上列性能基于进气温度20°C, 进水温度15°C, 排气压力1013hpa的条件, 被吸入气体为饱和空气(饱和空气是指在对应吸入的状态下, 其相对湿度为100%的湿空气)。
2. 当吸入绝压  $\geq 200$ hPa时, 性能允差  $\pm 5\%$ 。

转速 Speed r/min	不同吸入压力下的供水量 Operating liquid(water) at various inlet pressure		
	200~400mbar m³/h	400~600mbar m³/h	> 600mbar m³/h
472	5.0~5.5	4.5~5.0	2.1~3.1
490	5.2~5.7	4.6~5.2	2.2~3.3
530	5.4~6.0	4.9~5.4	2.3~3.4
590	6.5~6.8	5.8~6.5	2.6~3.6

1hPa(百帕)=0.75Torr(托) = 1mbar(毫巴)  
1Torr(托)=1.332hPa(百帕) = 1.332mbar(毫巴)

抽气速率、轴功率曲线

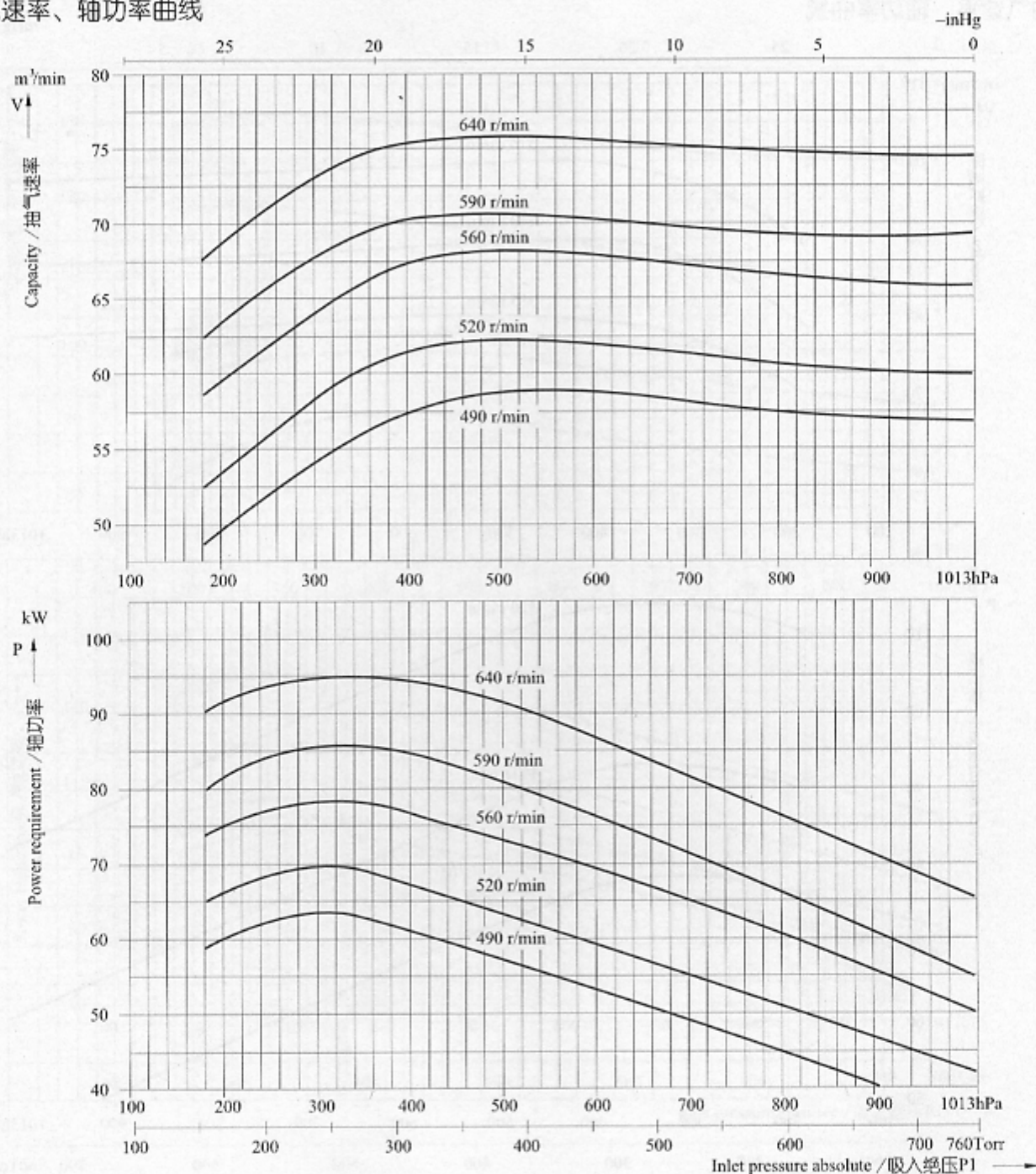

注:

1. 上列性能基于进气温度20°C, 进水温度15°C, 排气压力1013hpa 的条件, 被吸入气体为饱和空气(饱和空气是指在对应吸入的状态下, 其相对湿度为100%的湿空气)。
2. 当吸入绝压  $\geq 200$ hPa时, 性能允差  $\pm 5\%$ 。

转速 Speed r/min	不同吸入压力下的供水量 Operating liquid(water) at various inlet pressure		
	200~400mbar m³/h	400~600mbar m³/h	> 600mbar m³/h
490	8.0~9.5	5.0~8.0	3.0~5.0
520	8.5~10.0	5.5~8.5	3.2~5.5
560	9.0~10.5	6.0~9.0	3.5~6.0
590	9.5~11.5	6.5~9.5	3.7~6.5
640	10.5~12.5	10.0~7.0	4.0~7.0

1hPa(百帕)=0.75Torr(托) = 1mbar(毫巴)  
1Torr(托)=1.332hPa(百帕) = 1.332mbar(毫巴)

### 抽气速率、轴功率曲线

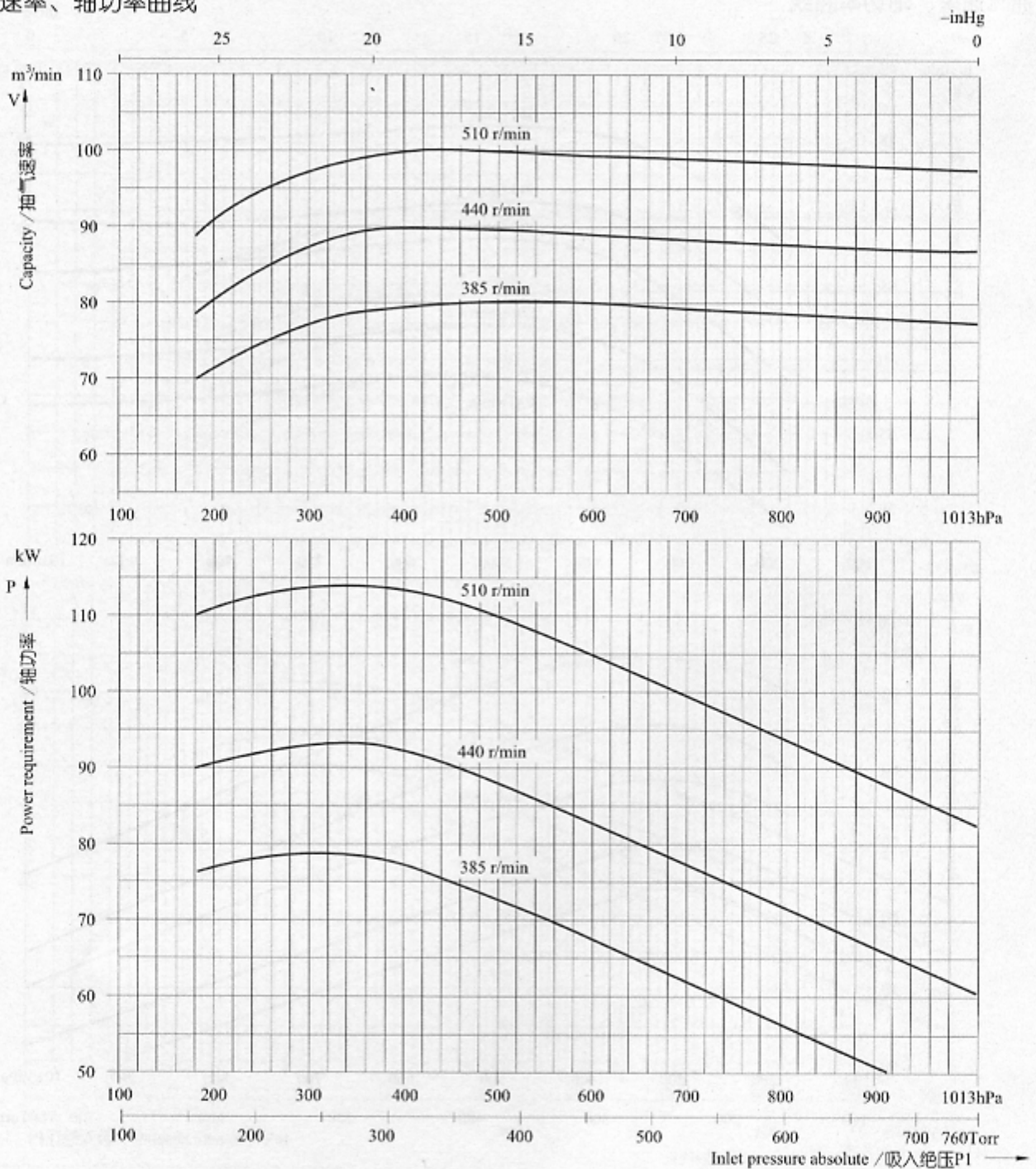

注:

1. 上列性能基于进气温度20°C, 进水温度15°C, 排气压力1013hpa的条件, 被吸入气体为饱和空气(饱和空气是指在对应吸入的状态下, 其相对湿度为100%的湿空气)。
2. 当吸入绝压 $\geq 200$ hPa时, 性能允差 $\pm 5\%$ 。

转速 Speed r/min	不同吸入压力下的供水量 Operating liquid(water) at various inlet pressure		
	200-400mbar m³/h	400-600mbar m³/h	> 600mbar m³/h
385	8.0-10.0	6.0-8.0	4.0-6.0
440	9.0-11.0	5.5-9.0	5.0-7.0
510	10.5-12.0	8.0-10.0	6.0-8.0

1hPa(百帕)=0.75Torr(托)=1mbar(毫巴)  
 1Torr(托)=1.332hPa(百帕)=1.332mbar(毫巴)



### 抽气速率、轴功率曲线

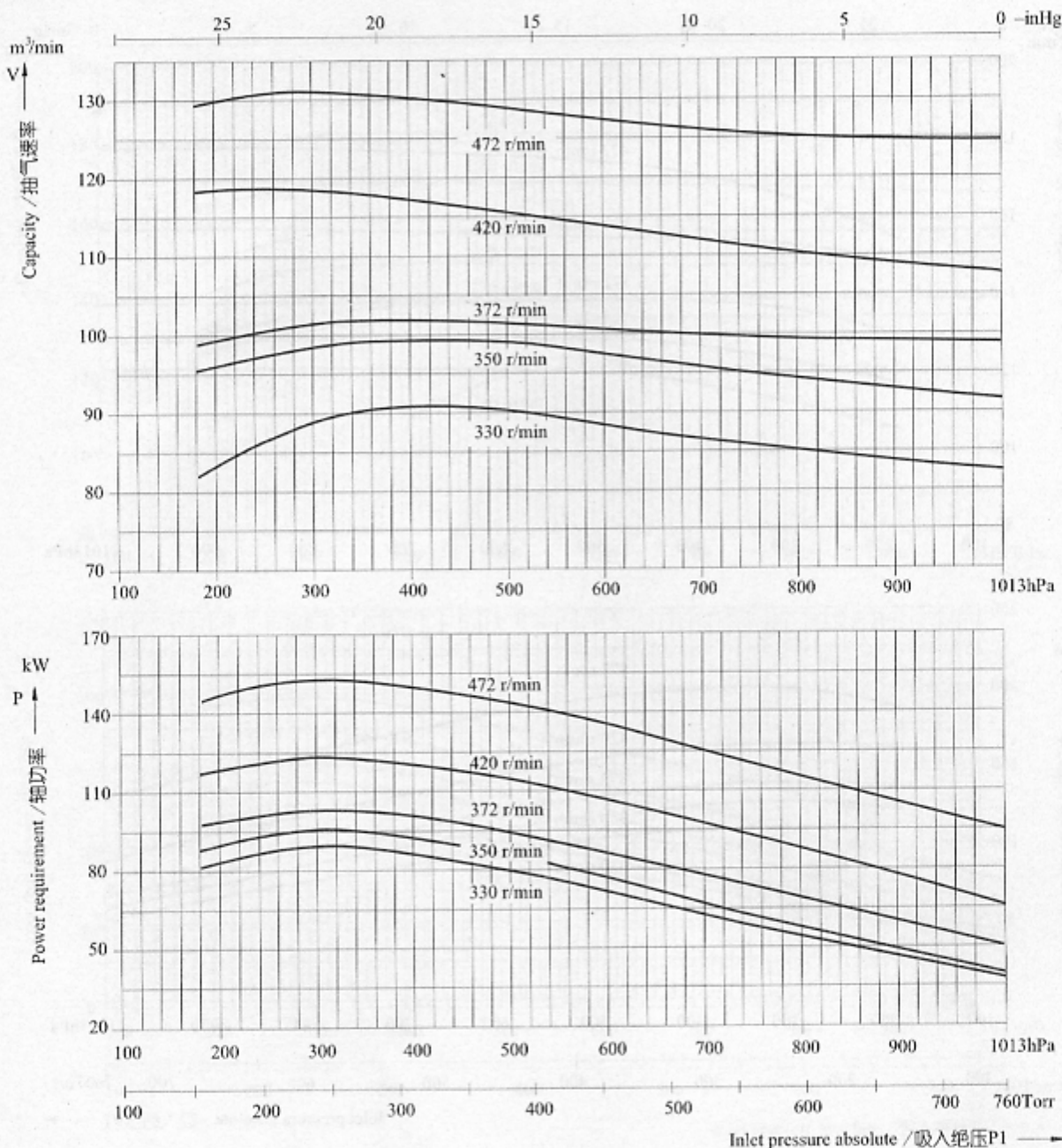

注:

- 1、上列性能基于进气温度20°C, 进水温度15°C, 排气压力1013hpa的条件, 被吸入气体为饱和空气(饱和空气是指在对应吸入的状态下, 其相对湿度为100%的湿空气)。
- 2、当吸入绝压 $\geq 200$ hPa时, 性能允差 $\pm 5\%$ 。

转速 Speed r/min	不同吸入压力下的供水量 Operating liquid(water) at various inlet pressure		
	200-400mbar m³/h	400-600mbar m³/h	> 600mbar m³/h
330	9.5-10.5	8.0-9.0	4.0-5.0
350	10.0-11.0	8.5-9.5	4.2-5.3
372	11.0-12.0	9.0-10.0	4.5-5.5
420	12.5-13.5	10.0-11.0	5.0-6.0
472	13.5-14.0	11.5-12.5	5.5-6.5

1hPa(百帕)=0.75Torr(托)=1mbar(毫巴)  
1Torr(托)=1.332hPa(百帕)=1.332mbar(毫巴)

### 抽气速率、轴功率曲线

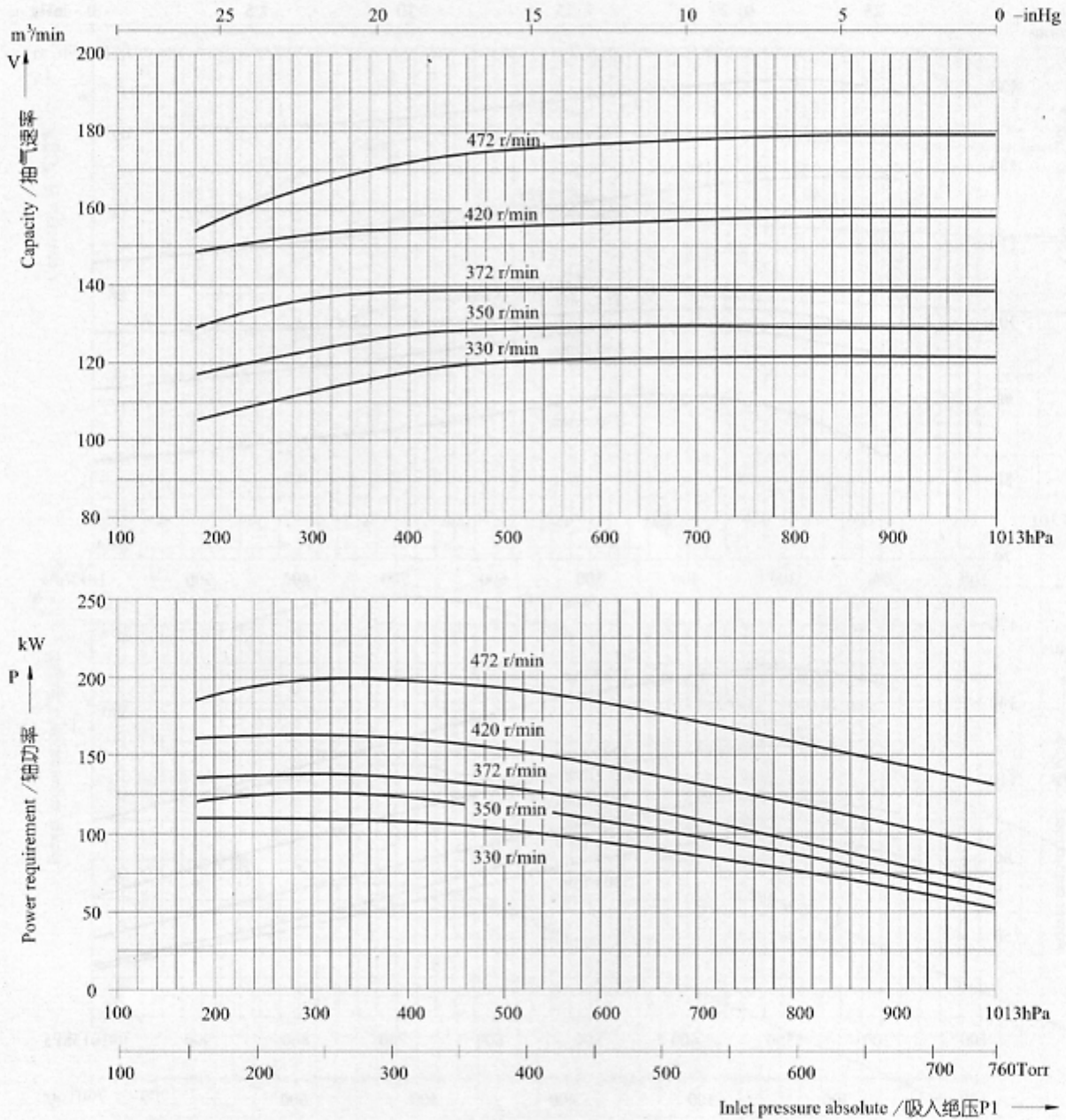

注:

- 1、上列性能基于进气温度20°C, 进水温度15°C, 排气压力1013hPa的条件, 被吸气体为饱和空气(饱和空气是指在对应吸入的状态下, 其相对湿度为100%的湿空气)。
- 2、当吸入绝压 $\geq 200$ hPa时, 性能允差 $\pm 5\%$ 。
- 3、当泵体带隔板时, 泵的型号为CBF416-2。

转速 Speed r/min	不同吸入压力下的供水量 Operating liquid(water) at various inlet pressure		
	200~400mbar m³/h	400~600mbar m³/h	> 600mbar m³/h
330	12.7~14.0	10.6~12.0	5.3~6.7
350	13.3~14.6	11.3~12.6	5.6~7.0
372	14.6~16.0	12.0~13.3	6.0~7.3
420	16.6~18.0	13.3~14.6	6.7~8.0
472	18.0~18.6	15.3~16.6	7.3~8.6

1hPa(百帕)=0.75Torr(托)=1mbar(毫巴)  
1Torr(托)=1.332hPa(百帕)=1.332mbar(毫巴)

### 抽气速率、轴功率曲线

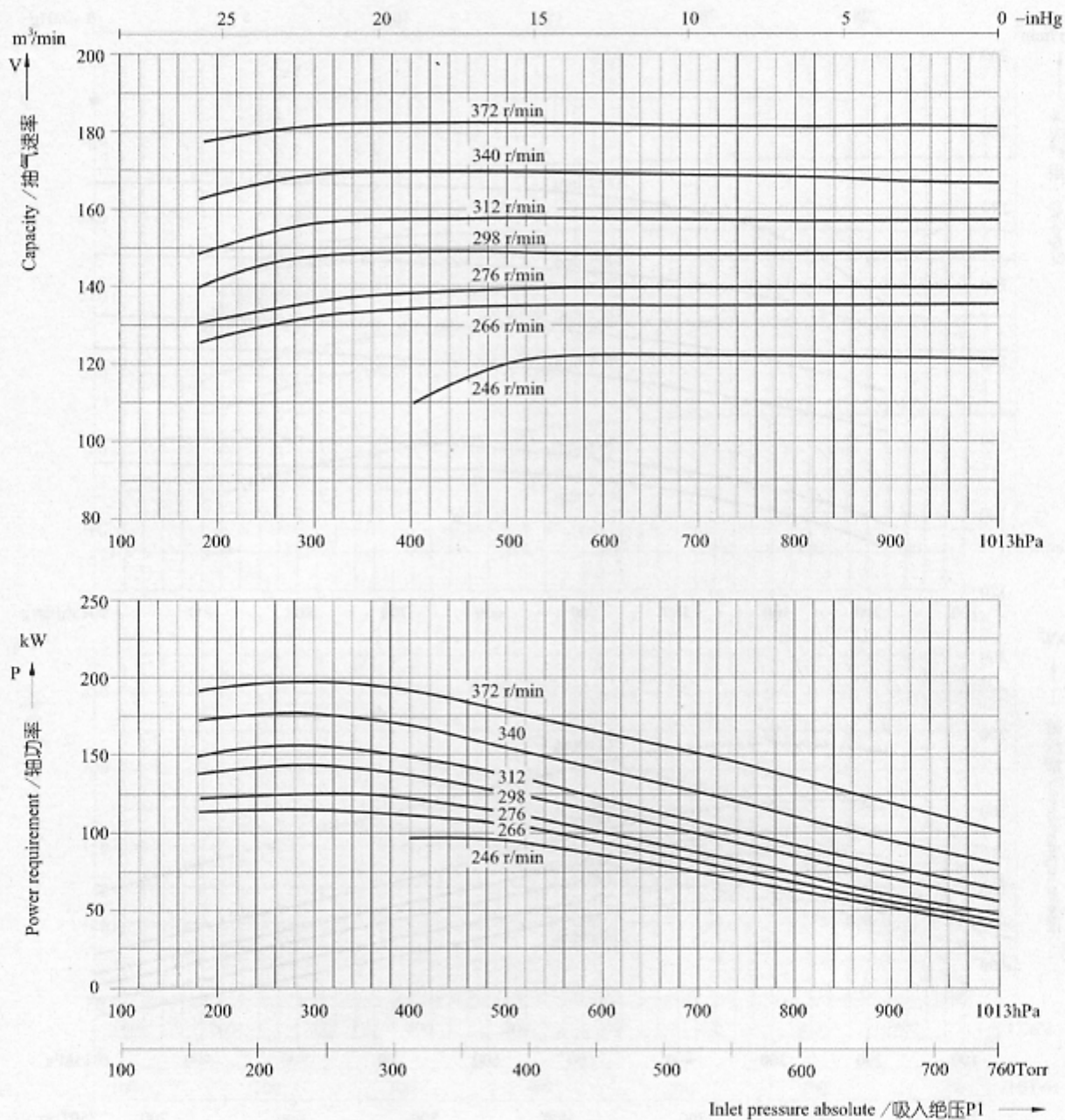

注:

- 1、上列性能基于进气温度20°C，进水温度15°C，排气压力1013hPa的条件，被吸入气体为饱和空气(饱和空气是指在对应吸入的状态下，其相对湿度为100%的湿空气)。
- 2、当吸入绝压>200hPa时，性能允差±5%。
- 3、当泵体带隔板时，泵的型号为CBF506-2。

转速 Speed r/min	不同吸入压力下的供水量 Operating liquid(water) at various inlet pressure		
	200~400mbar m³/h	400~600mbar m³/h	> 600mbar m³/h
246	9.5~10.5	8.0~9.0	4.0~5.0
266	13.0~14.9	9.5~13.0	6.1~9.5
276	13.5~15.4	10.0~13.5	6.6~10.0
298	14.5~16.5	10.6~14.5	6.8~10.6
312	15.2~17.3	11.3~15.2	7.5~11.3
340	16.2~18.5	11.8~16.2	8.2~11.8
372	18.2~20.5	13.3~18.2	8.5~13.3

1hPa(百帕)=0.75Torr(托)=1mbar(毫巴)  
1Torr(托)=1.332hPa(百帕)=1.332mbar(毫巴)

### 抽气速率、轴功率曲线

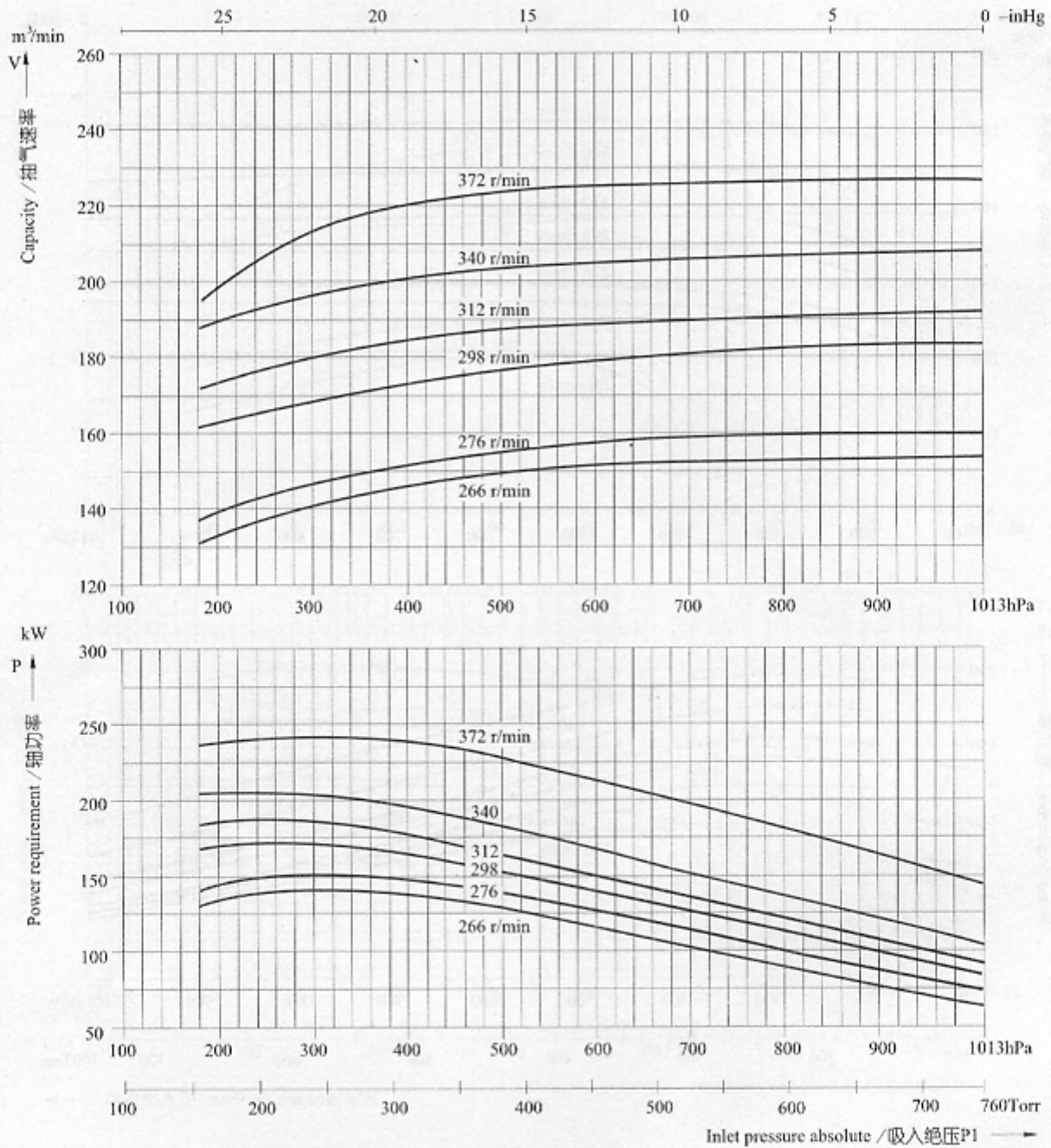

注:

- 1、上列性能基于进气温度20°C，进水温度15°C，排气压力1013hPa的条件，被吸入气体为饱和空气(饱和空气是指在对应吸入的状态下，其相对湿度为100%的湿空气)。
- 2、当吸入绝压 $\geq 200\text{hPa}$ 时，性能允差 $\pm 5\%$ 。
- 3、当泵体带隔板时，泵的型号为CBF516-2。

转速 Speed r/min	不同吸入压力下的供水量 Operating liquid(water) at various inlet pressure		
	200~400mbar m³/h	400~600mbar m³/h	> 600mbar m³/h
266	13.0~14.9	9.5~13.0	6.1~9.5
276	13.5~15.4	10.0~13.5	6.6~10.0
298	14.5~16.5	10.6~14.5	6.8~10.6
312	15.2~17.3	11.3~15.2	7.5~11.3
340	16.2~18.5	11.8~16.2	9.3~11.8
372	21.1~23.8	15.4~21.1	9.9~15.4

1hPa(百帕)=0.75Torr(托)=1mbar(毫巴)  
1Torr(托)=1.332hPa(百帕)=1.332mbar(毫巴)

### 抽气速率、轴功率曲线

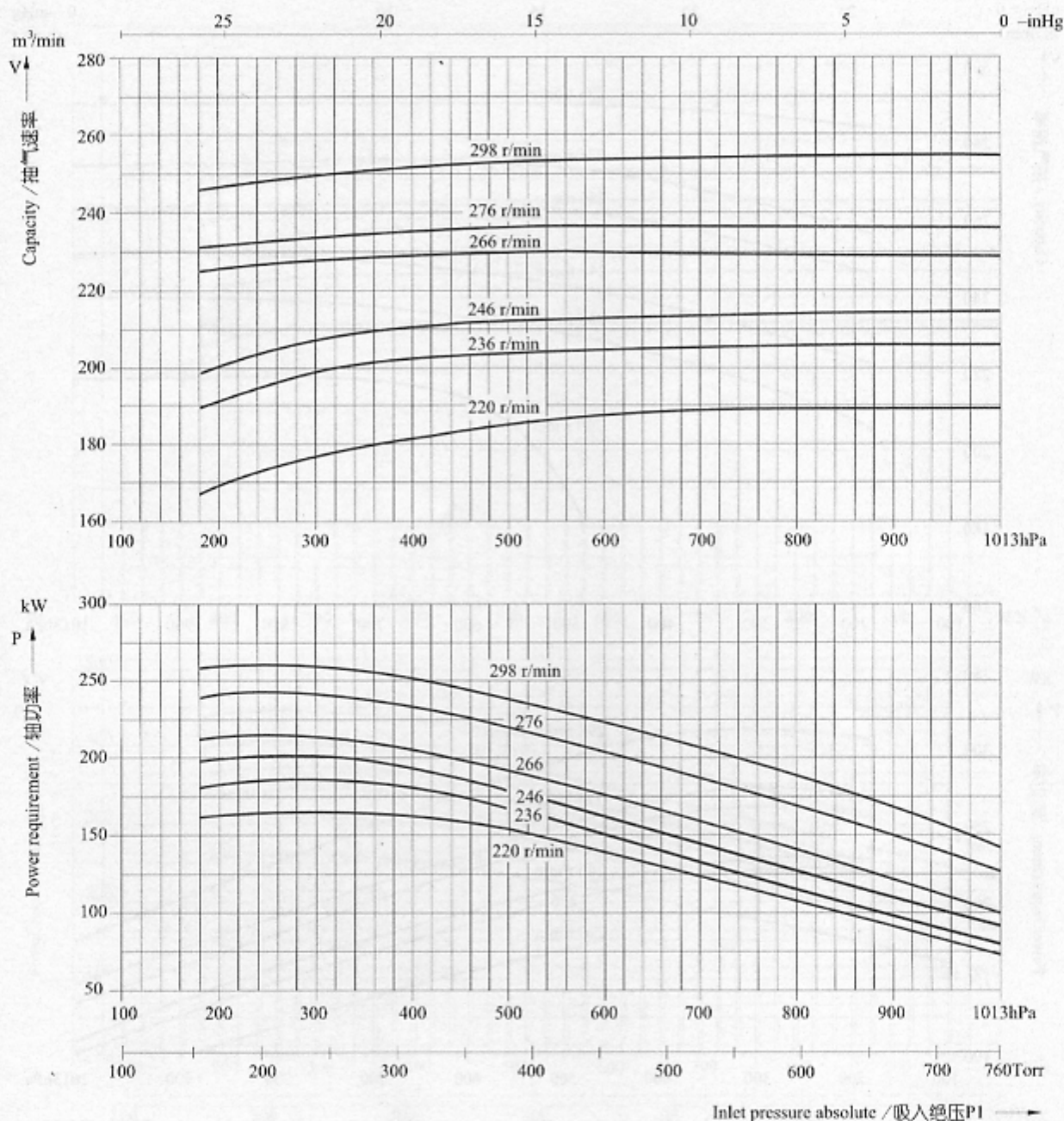

注:

- 1、上列性能基于进气温度20°C, 进水温度15°C, 排气压力1013hPa的条件, 被吸入气体为饱和空气(饱和空气是指在对应吸入的状态下, 其相对湿度为100%的湿空气)。
- 2、当吸入绝压 $\geq 200$ hPa时, 性能允差 $\pm 5\%$ 。
- 3、当泵体带隔板时, 泵的型号为CBF606-2。

转速 Speed r/min	不同吸入压力下的供水量 Operating liquid(water) at various inlet pressure		
	200-400mbar m <sup>3</sup> /h	400-600mbar m <sup>3</sup> /h	> 600mbar m <sup>3</sup> /h
220	17.6~20.7	14.5~17.6	8.3~12.9
236	18.9~22.2	13.8~18.9	8.9~13.8
246	19.7~23.1	14.4~19.7	9.3~14.4
266	21.3~25.0	15.6~21.3	10.0~15.6
276	21.8~25.5	16.1~21.8	10.5~16.1
298	23.9~27.5	17.5~23.9	11.2~17.5

1hPa(百帕)=0.75Torr(托)=1mbar(毫巴)

1Torr(托)=1.332hPa(百帕)=1.332mbar(毫巴)

### 抽气速率、轴功率曲线

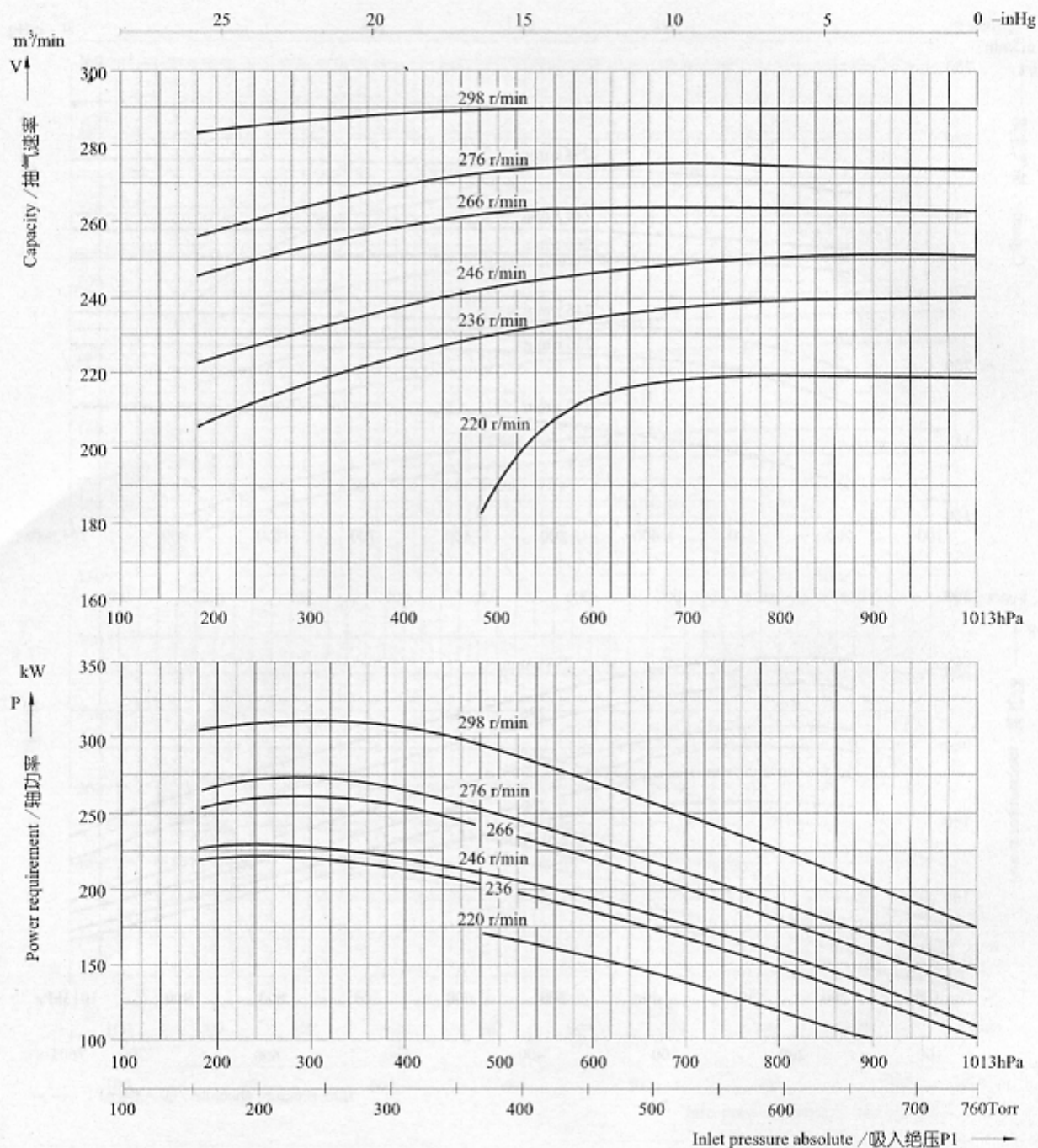

注:

- 1、上列性能基于进气温度20°C，进水温度15°C，排气压力1013hPa的条件，被吸入气体为饱和空气(饱和空气是指在对应吸入的状态下，其相对湿度为100%的湿空气)。
- 2、当吸入绝压 ≥ 200hPa时，性能允差 ± 5%。
- 3、当泵体带隔板时，泵的型号为CBF616-2。

转速 Speed r/min	不同吸入压力下的供水量 Operating liquid(water) at various inlet pressure		
	200~400mbar m³/h	400~600mbar m³/h	> 600mbar m³/h
220	20.4~24.0	14.9~20.4	9.6~14.9
236	21.9~25.8	16.0~21.9	10.3~16.0
246	22.9~26.8	16.7~22.9	10.7~16.7
266	24.7~29.0	18.1~24.7	11.6~18.1
276	25.3~29.6	18.7~25.5	12.2~18.7
298	27.7~31.9	20.3~27.7	13.0~20.3

1hPa(百帕)=0.75Torr(托) = 1mbar(毫巴)  
1Torr(托)=1.332hPa(百帕) = 1.332mbar(毫巴)

### 抽气速率、轴功率曲线

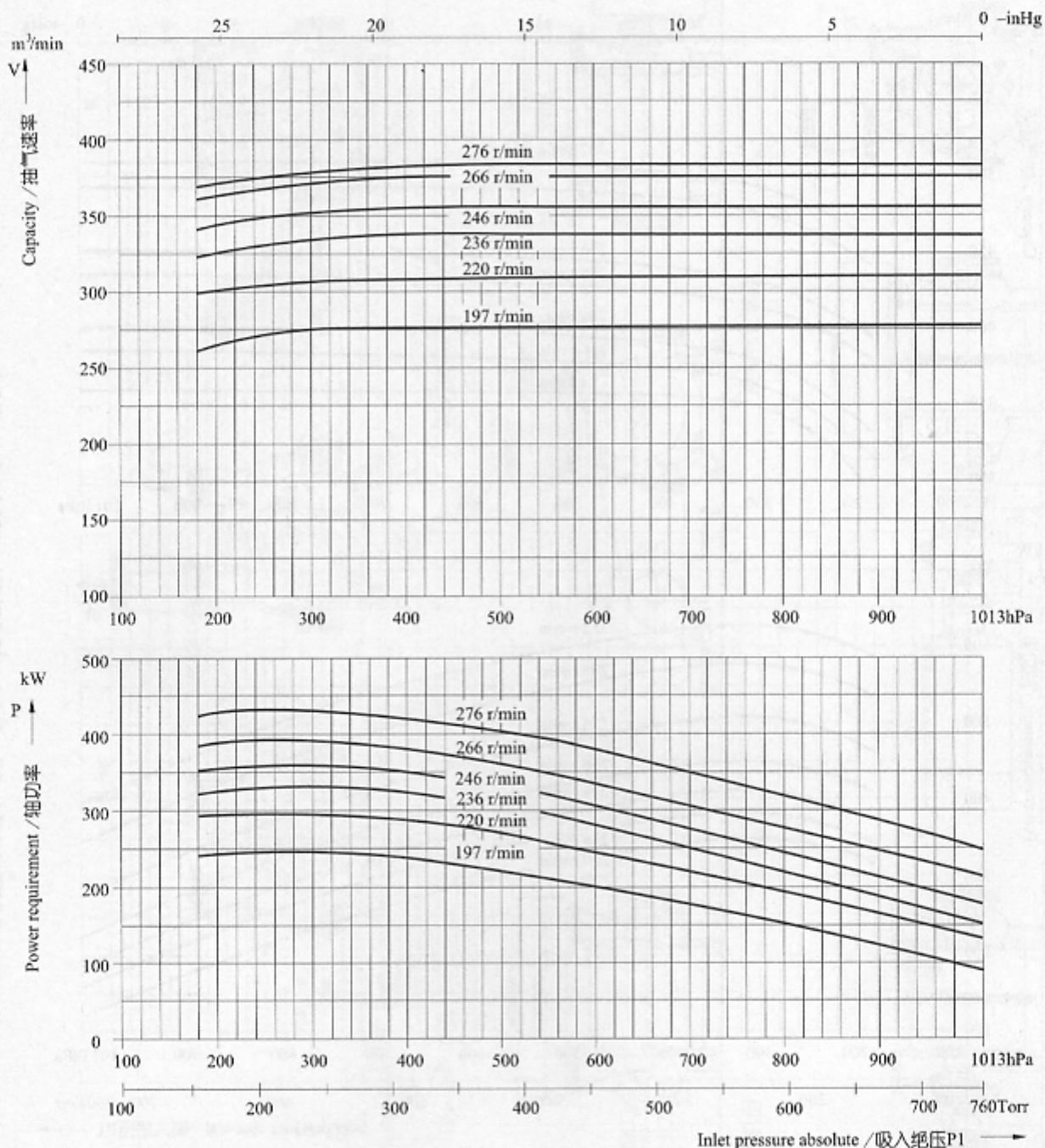

注:

- 1、上列性能基于进气温度20°C，进水温度15°C，排气压力1013hPa的条件，被吸入气体为饱和空气(饱和空气是指在对应吸入的状态下，其相对湿度为100%的湿空气)。
- 2、当吸入绝压 $\geq 200$ hPa时，性能允差 $\pm 5\%$ 。
- 3、当泵体带隔板时，泵的类型为CBF706-2。

转速 Speed r/min	不同吸入压力下的供水量 Operating liquid(water) at various inlet pressure		
	200~400mbar m³/h	400~600mbar m³/h	> 600mbar m³/h
197	26.3~28.3	19.0~26.3	12.0~19.0
220	29.5~34.2	21.6~29.5	14.5~21.6
236	31.4~37.3	24.1~31.4	15.0~24.1
246	32.5~38.4	25.2~32.5	15.7~25.2
266	35.1~42.7	26.4~35.1	19.4~26.4
276	36.2~43.8	27.5~36.2	20.5~27.5

1hPa(百帕)=0.75Torr(托) = 1mbar(毫巴)  
1Torr(托)=1.332hPa(百帕) = 1.332mbar(毫巴)

### 抽气速率、轴功率曲线

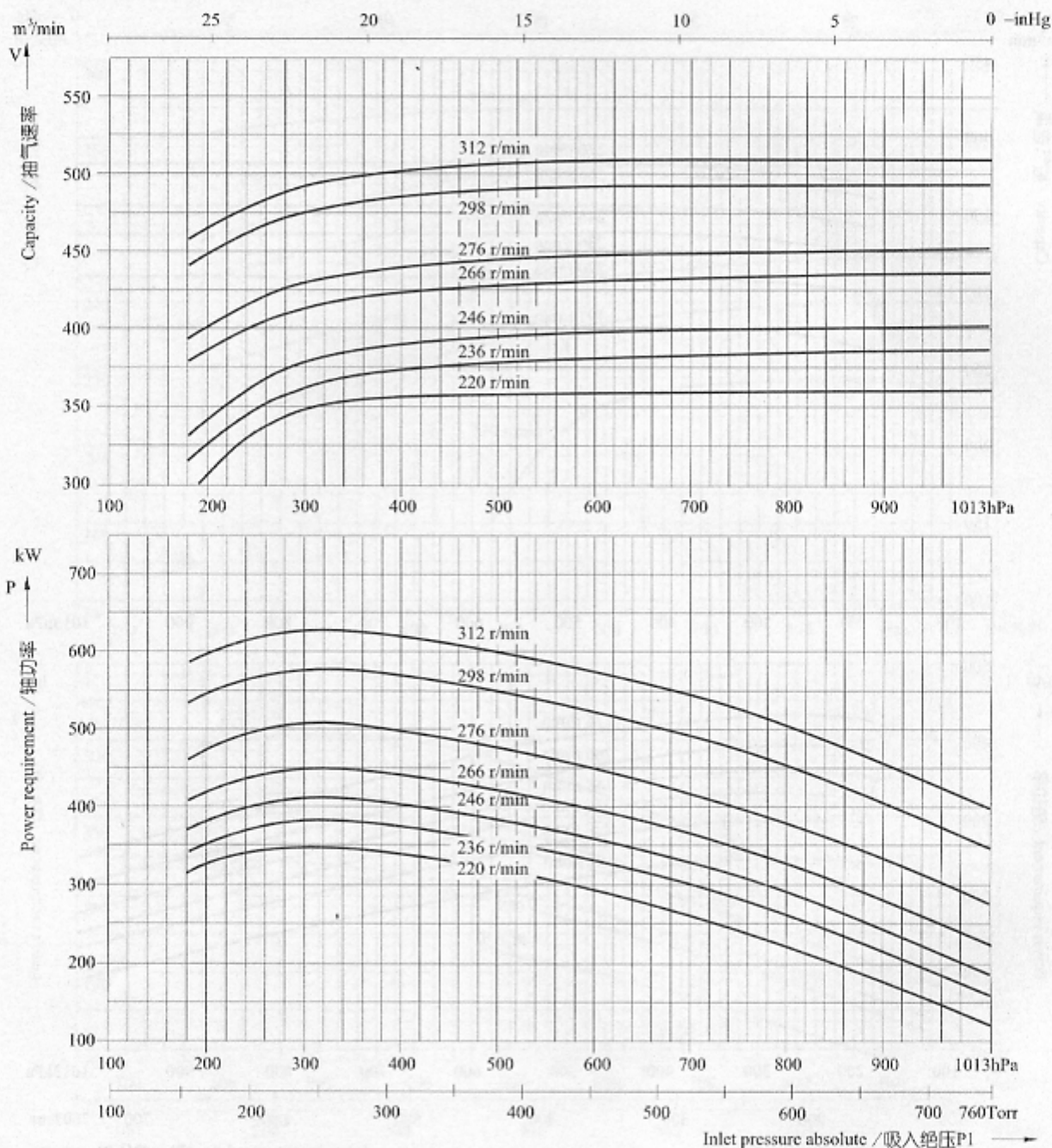

注:

- 1、上列性能基于进气温度20°C，进水温度15°C，排气压力1013hPa的条件，被吸入气体为饱和空气(饱和空气是指在对应吸入的状态下，其相对湿度为100%的湿空气)。
- 2、当吸入绝压 $\geq 200$ hPa时，性能允差 $\pm 5\%$ 。
- 3、当泵体带隔板时，泵的型号为CBF716-2。

转速 Speed r/min	不同吸入压力下的供水量 Operating liquid(water) at various inlet pressure		
	200~400mbar m³/h	400~600mbar m³/h	> 600mbar m³/h
220	28.5~38.4	28.5~25.2	25.2~16.7
236	32.6~43.2	32.6~28.9	28.9~18.8
246	33.4~44.8	33.4~30.3	30.3~19.5
266	36.3~48.5	36.3~32.5	32.5~20.5
276	37.6~50.7	37.6~33.5	33.5~21.8
298	40.6~54.7	40.6~36.2	36.2~23.5

1hPa(百帕)=0.75Torr(托)=1mbar(毫巴)  
1Torr(托)=1.332hPa(百帕)=1.332mbar(毫巴)



CBF 水环真空泵进、排气方式及机组传动方式示意图

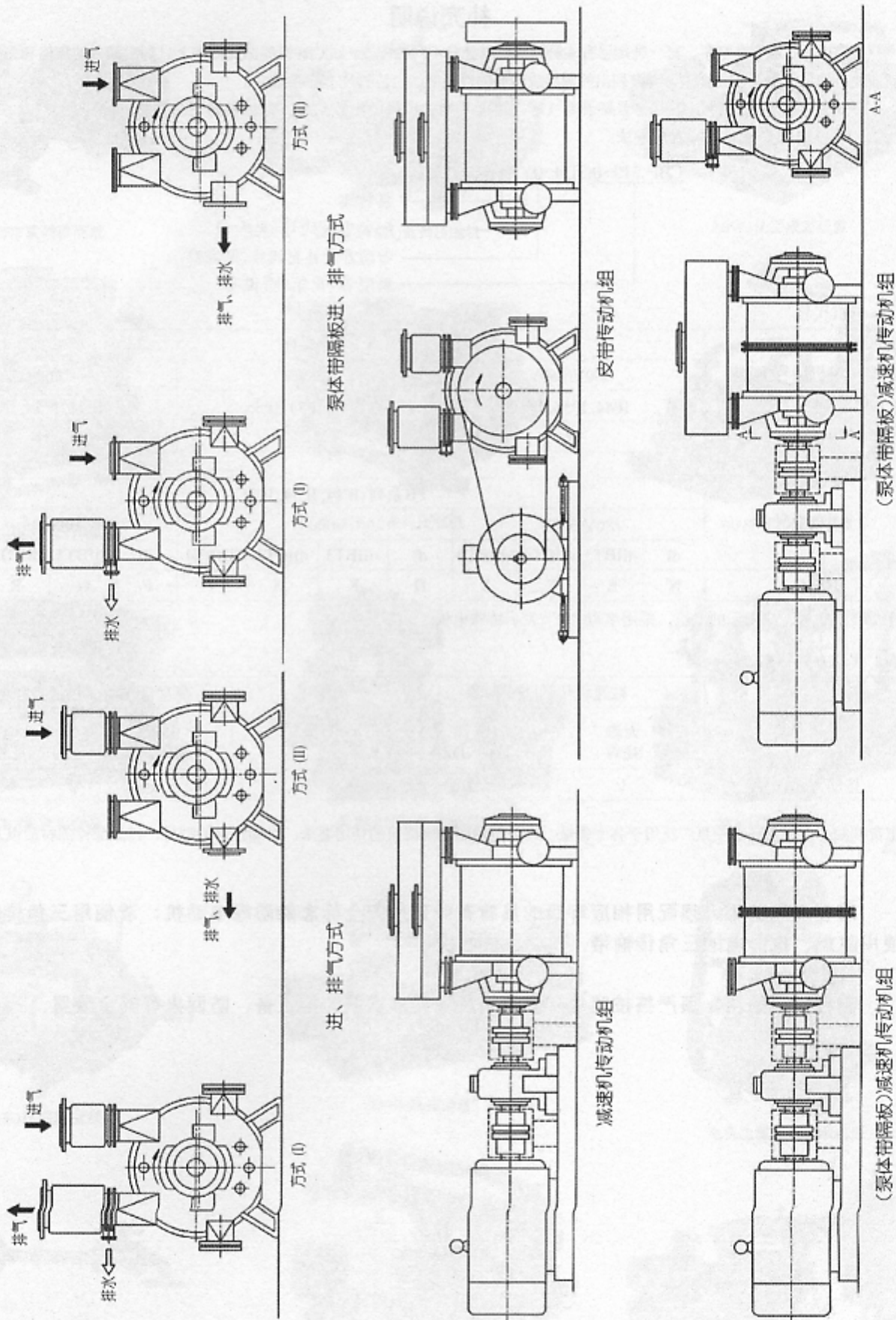

## 补充说明

(1) CBF系列水环真空泵，每一种规格有多种材质、转速和不同的配置，此CBF性能曲线样本上只列出部分的规格和部分转速的性能曲线，如果你需要在此样本上没有列出的规格或转速的性能曲线，请与技术部联系。

(2) 如果水环真空泵排出压力要求高于大气压，可能要增大电机的配置功率，具体参数请与技术部联系。

(3) 水环真空泵机组型号表示方法：



表1 电机代号

电机型号	Y系列		
	380V/660V	6000V	10000V
	IP44, IP54, IP55	IP44, IP54, IP55	IP44, IP54, IP55
电机代号	Y	C	H

电机型号	YB系列(IP44, IP54, IP55)											
	380V/660V				6000V				10000V			
	dI	dIIBT3	dIICT4	dIIBT4	dI	dIIBT3	dIICT4	dIIBT4	dI	dIIBT3	dIICT4	dIIBT4
电机代号	N	E	P	S	D	K	M	J	F	G	R	U

注：表中代号无法表示的电机，采用字母“T”表示特殊电机。

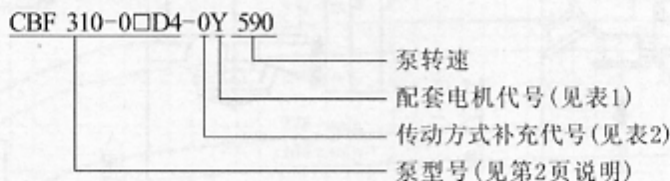
表2 传动方式补充代号

传动类别	减速机传动（平行轴）		直联传动	窄V带传动（包括防静电皮带）	
	天津 SEW	天津 FLENDER		电机在 泵的左侧	电机在 泵的右侧
传动方式代号	1	2	0	1	2

定货须知：由于水环真空泵广泛用于各个领域，用户定货时请明确泵的使用要求，以确定泵的类型、过流部件的材质以及机组配套。

若在煤矿使用，须配用相应等级的具有有效矿用安全标志的防爆电动机；若使用三角传输带，应使用阻燃、抗静电的三角传输带。

若在煤矿使用，须严格按照煤矿安全规程的要求安装监控设备、防回火等安全装置。